

# Cutting-edge Performance and Reliability



Highest Power Density



Most Power in 3U Space

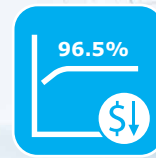

Leading Energy Efficiency



Battery Health Prediction

The power behind competitiveness

## Delta UPS - Modulon Family DPH Series, 50-300/500/600kVA

The highest power density with uncompromised power performance and reliability

# About Delta Group

## Leading expert in power management and thermal management solutions

Delta Group is the world's leading provider of power management and thermal management solutions, as well as a major source for components, visual displays, industrial automation, networking products, and renewable energy solutions. Delta Group is focused on three main businesses: power electronics, energy management, and smart green life. Delta Group has sales offices worldwide and manufacturing plants in Taiwan, China, Thailand, Japan, Mexico, India, Brazil and Europe.

As a global leader in power electronics, Delta's mission is, "To provide innovative, clean and energy-efficient solutions for a better tomorrow." Delta is committed to environmental protection and has implemented green, lead-free production and recycling and waste management programs for many years.

**World no. 1** in Switching Power Supplies, DC Brushless Fans and Telecom Power Systems

**153** sales offices and **39** manufacturing facilities worldwide

**5-6%** of annual sales revenues invested in R&D with over **7,000** engineers

in **64** R&D centers worldwide

Awarded **7,100+** patents and received **47** internationally recognized design awards including iF, Reddot, and the Taiwan Excellence awards.

## Worldwide No. 1 supplier of merchant power supplies

According to the IHS report, Delta Electronics remained the largest supplier of merchant power supplies with an estimated market share of 15.5% in 2016 of a global market value that was estimated to be \$21,869 million.

### The Total Merchant Power Supply Market 2016 \$M Revenue

Ranking	Company Name	Market Share
1	Delta Electronics	15.5%
2	Artesyn	7.5%
3	Lite-on Technology	4.5%

Source: AC-DC & DC-DC Merchant Power Supplies, IHS, 2017

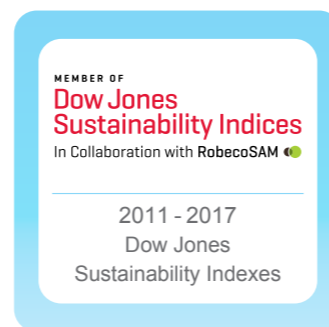

More information about Delta Group can be found at <http://www.deltaww.com/>

# Delta InfraSuite Data Center Infrastructure Solutions

Enterprise growth and IT equipment have become so closely linked that planning and building a high performance data room is one of the critical issues for IT managers today.

With 45 years of leadership in the core technologies of power electronics, the expert teams at Delta Electronics have developed a new generation of data center infrastructure solutions: InfraSuite.

Delta InfraSuite includes power system, rack and accessories, precision cooling, and environment management system.

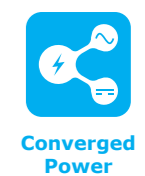
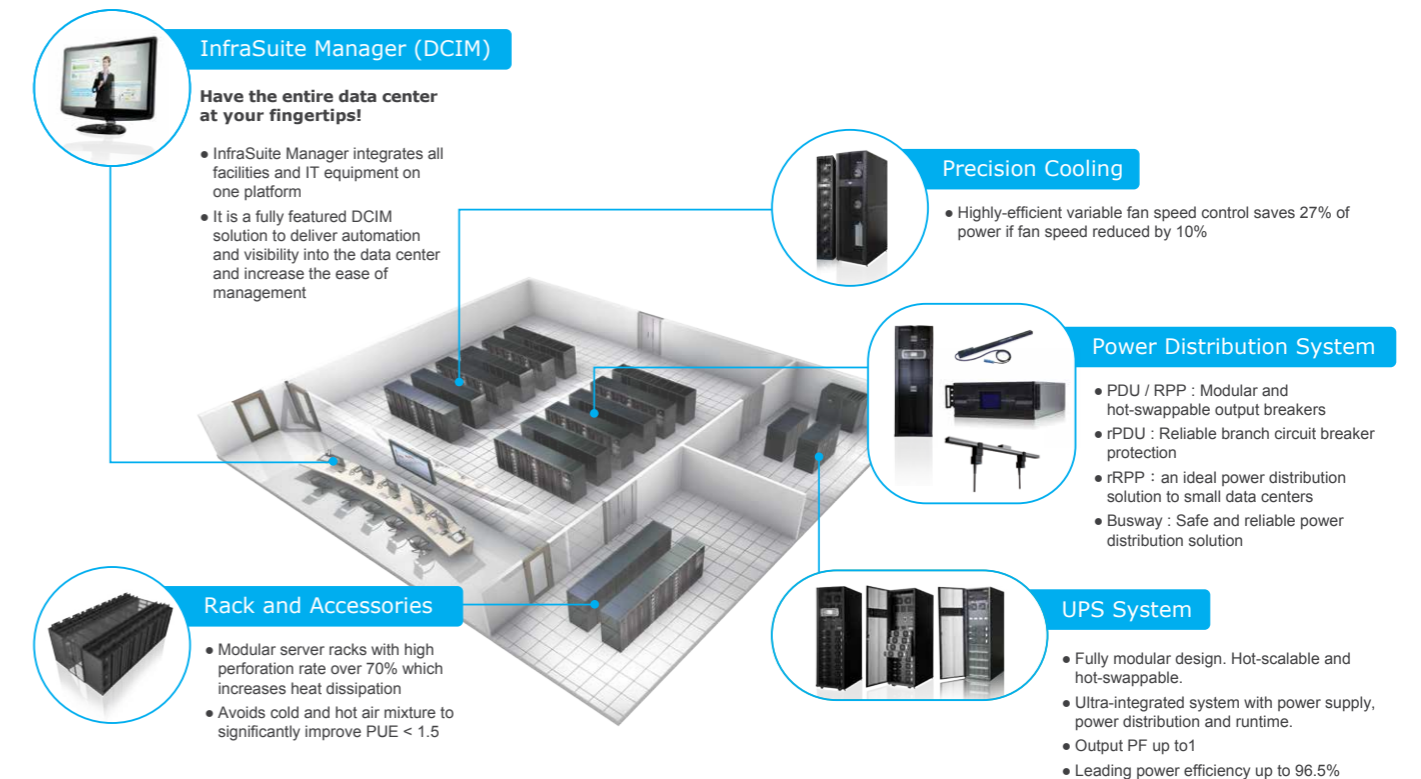

Delta Data Center Solutions  
[www.deltapowersolutions.com](http://www.deltapowersolutions.com)



# Big Density for Big Data

Increasing digitization expands the global need for compute and storage. IT managers must respond to growing IP data traffic with only limited data center space. Content-heavy applications such as bandwidth-intensive video streaming, the Internet of Things (IoT), VR/AR and big data are generating considerable additional traffic, resulting in demand for greater data center capacity. That has made scalability and flexibility driving forces in infrastructure innovation.

Delta's innovative modular UPS technologies give customers the high power density, power performance, and availability they need to succeed in the face of these challenges. This high density makes oversizing – one of the major drivers of excess data center cost – avoidable right from design phase.

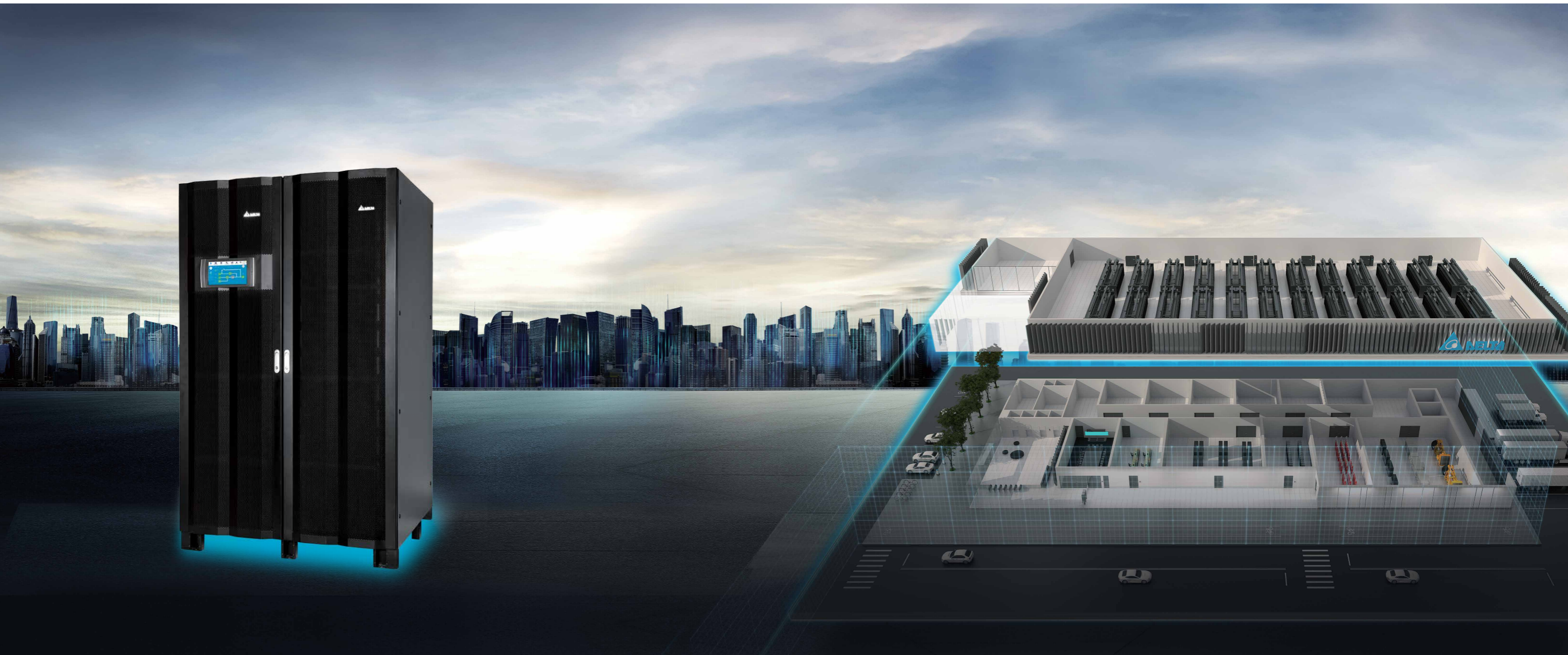

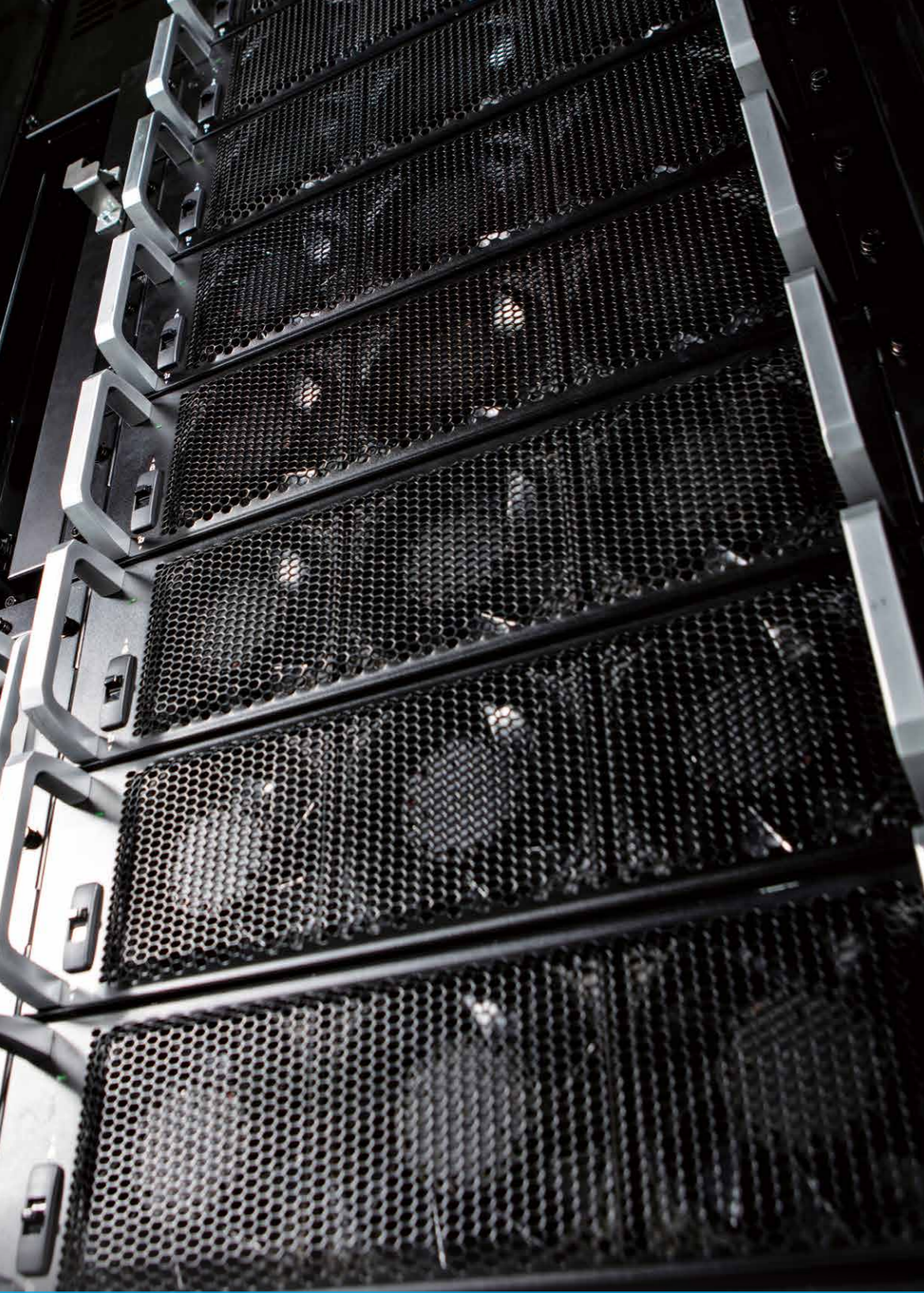

# Modulon DPH series UPS 50-300/500/600 kVA

The world's highest power density UPS providing ultimate MW power protection with leading power performance and superior reliability

Delta's state-of-the-art online double conversion UPS is available in capacities of up to 600kVA with record-setting high density power modules of 50kW. Data center operators can save more power room space with cabinets that are only half the width of most competing models. Besides high power performance and efficiency, the new Modulon DPH series UPS also offers advanced failure detection and event analysis capabilities to ensure outstanding reliability for large scale data centers.

Modulon DPH UPSs give customers greater flexibility to meet their backup power requirements, such as for CORD (central office re-architected as a data center) or edge data centers in the telecommunication segment. Delta offers a broad range of modular UPSs for diverse mission critical applications.

- 1 Standard 19" rack dimension
- 2 10" color touch screen
- 3 Control module
- 4 Static transfer switch module
- 5 High density power module 50kW in 3U space
- 6 Input, output, bypass and maintenance bypass breakers
- 7 Bypass switch
- 8 Input, output and maintenance bypass switches
- 9 Input, output, bypass and maintenance bypass switches



300/500kVA



600kVA



300kVA



500kVA

Switch Cabinet (Optional)



600kVA



Performance



Availability



Manageability

# Pay-as-you-go Architecture with Ultra Compact Design

The industry-leading power density of 55.6kVA/50kW per 3U module achieved by Delta's new Modulon DPH UPS gives data center operators the flexibility to adapt to rapidly changing requirements. Delta's Modulon DPH series UPS offers both the highest power density per module and the smallest footprint available, achieving 500kVA in a single rack and 600 kVA in two racks to make the most out of the available space.

This high power density means less space is consumed by power infrastructure. That helps avoid oversizing—one of the major drivers of excess data center cost. What's more, adding capacity later is simple and economical, unlike with conventional monoblock UPS solutions, which require enough capacity for the maximum data center load to be installed from the start. The flexibility and density of Delta's new Modulon DPH line translates to more room for revenue-generating IT racks and longer data center life cycles.

How were we able to achieve these specifications? In UPS design, high efficiency and high density are two sides of the same coin. Delta R&D experts first chose advanced high-speed IGBT semiconductor technology and low-loss magnetic components for the Modulon DPH family. They then optimized the layout and airflow management to reduce power loss and increase heat dissipation. The resulting design requires smaller heat sinks and fewer components. In the end, our engineers were able to fit 55.6kVA per power module in a mere 3U space - a testament to Delta's engineering capabilities.

Delta's engineering excellence is the secret behind the compact, high-power 3U module

**55.6 kVA**  
in 3U space



Modulon DPH 500kVA UPS

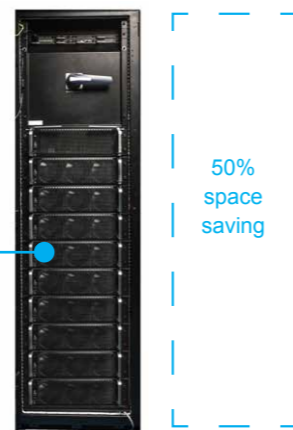

50%  
space  
saving

Competitor

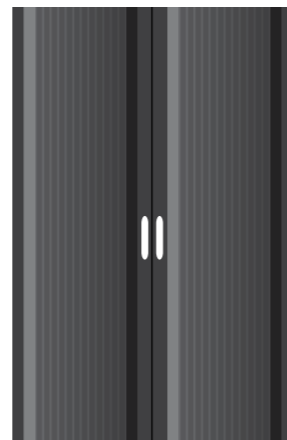

Delta's new DPH series UPS offers the highest power density available at 55.6 kVA/ 50kW in a three unit space. State-of-the-art technologies were used to design the device including optimized printed circuit board (PCB) layout placement, PFC interleaving technology, solid thermal simulation, and more.

Delta's ongoing pursuit of engineering excellence and leading position in the market reflects a deep commitment to serving our customers the world over.

# Excellent Power Performance and Efficiency

## Leading AC-AC efficiency in Online Mode

Delta is firmly committed to making data centers as green as possible. The Modulon DPH series UPS is the ecological choice with its AC-AC conversion efficiency of up to 96.5% in normal operation and 99% in ECO mode. This high energy efficiency results in considerable energy savings for large data centers.

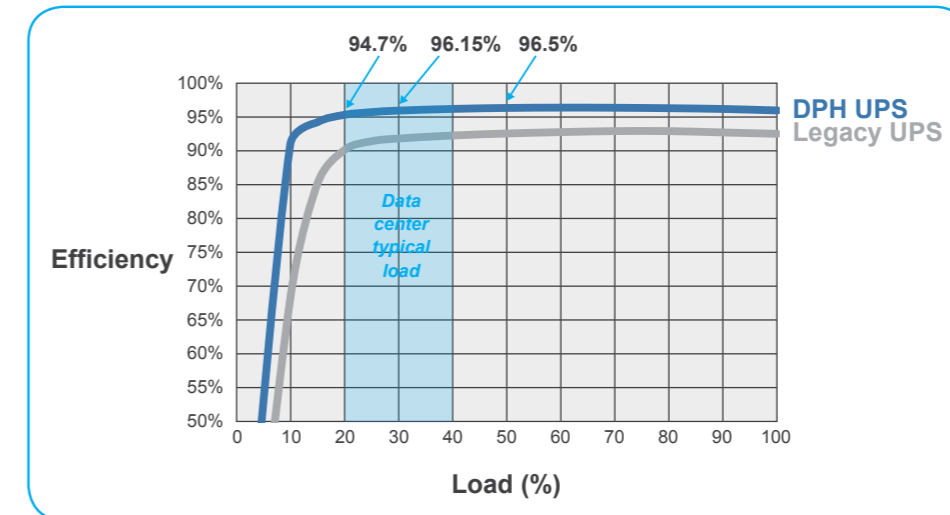

- AC-AC peak efficiency 96.5%
- AC-AC efficiency is around 95%, 20% under light loads
- Efficiency 99% in ECO mode

## Green Mode

All UPS vendors do their best to maximize AC-AC efficiency under full load. However, with N+X and 2N power architectures, a typical data center will operate under light loads of 30% to 40% or even less. That's why efficiency under light loads can sometimes be more important.

Delta's intelligent Green Mode enables UPS power aggregation across all power modules to boost AC-AC efficiency and reduce energy loss. The system will automatically detect the total load capacity percentage to decide which specific power modules should be fully powered on or idle in order to achieve higher efficiency of the UPS. When the load percentage is less than 40%, one power module will switch from online to standby mode every 30 seconds. And when load percentage is higher than 60% or load increases dramatically, the idle modules will be awakened in less than 5ms to ensure the continuous power supply to the load. What's more, the power modules will take turns switching over to standby mode for a long operating life.

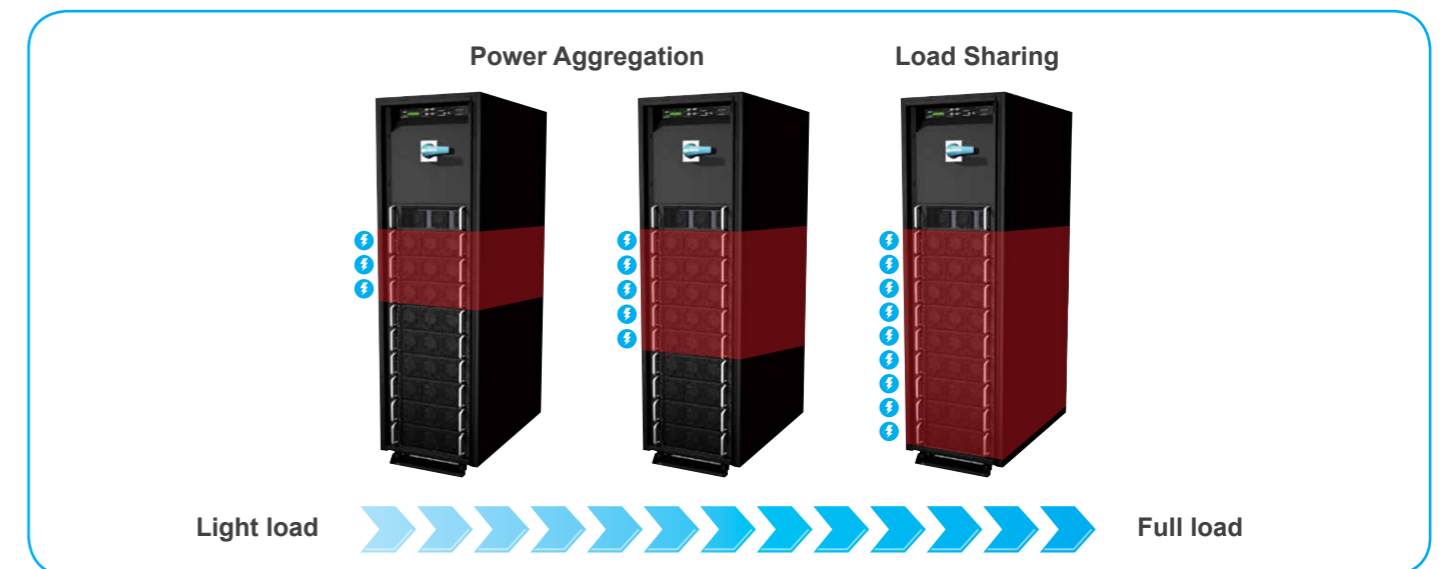

# Ultimate availability for mission critical operations

DPH series features the adaptable modular design that critical components are hot swappable. Furthermore, the state-of-the-art microprocessor technology in the DPH series self-detects key components and parameters and supports waveform recording. These advanced features enable accurate event analysis and diagnosis, making the DPH series suitable for high-availability applications.

## Pay as you go

Thanks to its modular design, Modulon DPH UPS systems enable advanced power module redundancy control and the ability to add capacity and pay as you grow.

Compared to traditional UPS systems, fully modular designs with hot-swappable key modules - including STS module, communication interfaces and power modules - can also cut the mean time to repair (MTTR) down to practically nothing and expand system capacity flexibly.



## Advanced event analysis

Modulon DPH UPS systems offer key parameters and waveform records supporting advanced event analysis and diagnosis.

- **Event triggers:** Mode switch, system shutdown and no output (drop load)
- **Waveform recording time frame:** Pre-event 70ms and post-event 30ms
- **Recorded parameters:** Output voltage, current wave display, battery voltage, DC bus voltage, input voltage wave display

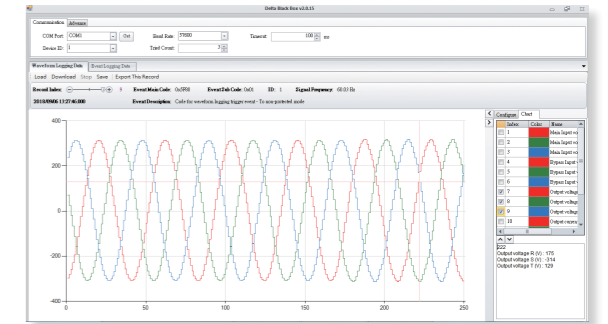

Software: Delta Black Box

## Proactive detection of key components

Modulon DPH series UPS owns the state-of-the-art microprocessor technology which performs proactive self-detection of key components including batteries, STS fans and AC/DC capacitors. The system can also provides complete and detailed operating status of the UPS. Alarm occurs proactively when abnormal situation is detected.

The battery set is critically important in the event of a power outage. Battery health is essential if operation is to continue uninterrupted. Modulon DPH UPS systems can carry out proactive battery testing, perform capacity detection, and even forecast how fast batteries are aging by collecting and analyzing data.



# Redundant design for high availability

The Modulon DPH series UPS is a highly redundant system that is used to achieve outstanding availability. By ensuring the design includes no single points of failure, Delta was able to build an extremely reliable solution. The resulting six-nines availability reflects best practice for optimizing the total cost of operating your data center.



## Controller & Signal Transmission

Expanded relay I/O card and lithium ion battery communication card (optional)

Dual controllers ensure reliable communication and enable parallel system redundancy and synchronization. The dual controller design provides a CAN bus redundancy, either inside the UPS system or between parallel systems as a daisy chain or ring connection.

Dual auxiliary power ports ensure continuous power supply.

## Power Module

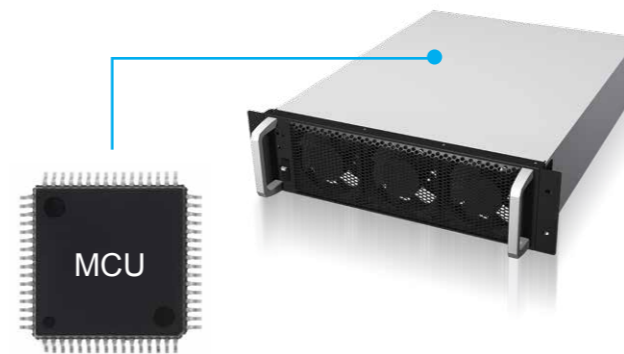

The fully fault-tolerant design provides self-redundancy to the control mechanism in power modules. Full control logic in each power module allows the system to self-synchronize in the event of control module failure and automatically switch to the backup for assured continuous operation.

## System



Parallel expansion and N+X redundancy can be implemented to meet the power requirements of MW-level data centers. Modular DPH series UPS systems grow with your business via parallel expansion with up to 8 units for 4.8 MW of total capacity.

# High manageability

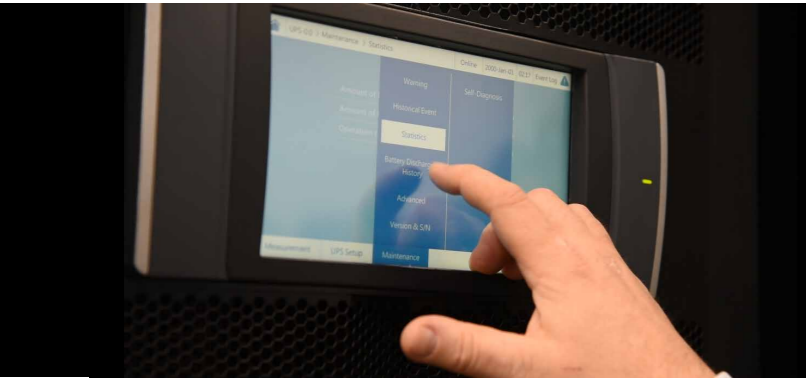

Delta's DPH series Modulon UPS offers the ability to view up to 10,000 event logs on the touch panel. The unit's 10" LCD screen can optionally display information on security, cooling, fire protection, and temperature in addition to battery status. The availability of all this information on the touchscreen of the UPS allows for easy local management.

## Battery Management System

If the UPS is equipped with an external battery management system, the battery information (including battery charge/discharge current, voltage, resistance and environment temperature) can be integrated into the UPS and monitored via the LCD of the UPS. It is also compatible with other vendors' BMS hardware through open protocol interface and firmware customization.

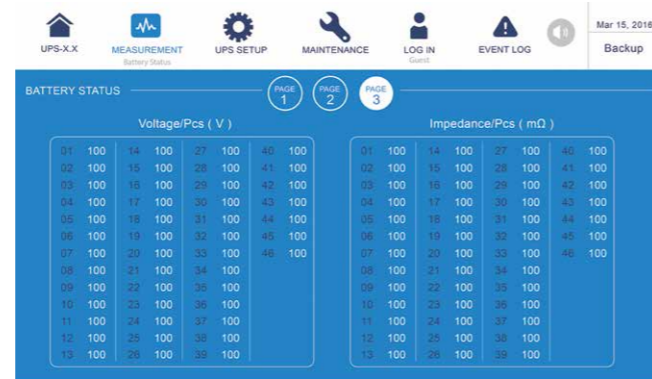

## Environment Management System

Up to 16 pieces of EnviroProbe can be connected to UPS via Ethernet for data collection such as security, water, fire and temperature.



## Power Consumption Management

For better facility management, facility managers can monitor the power consumption and get detailed energy usage analysis to understand the electricity tariff history by day / week / month / year.



Delta InfraSuite Manager DCIM solution is also available for option for more comprehensive data center infrastructure management.

# Technical Specifications

Model	DPH 300 System	DPH 500 System	DPH 600 System	
Power Rating	kVA	100,150,200,250,300	300,350,400,450,500*	500,550,600
	kW	100,150,200,250,300	300,350,400,450,450	500,550,600
	Power Module Quantity	Up to 6 units	Up to 9 units	Up to 12 units
Input	Nominal Voltage	220/380V, 230/400V, 240/415V (3-phase, 4-wire + G)		
	Voltage Range	176 ~ 276 Vac (full load)		
	Current Harmonic Distortion	< 3%**		
	Power Factor	> 0.99		
	Frequency Range	40 ~ 70 Hz		
Output	Voltage	220/380V, 230/400V, 240/415V (3-phase, 4-wire + G)		
	Voltage Harmonic Distortion	≤ 0.5% (linear load)		
	Voltage Regulation	±1% (static)		
	Frequency	50/60 ± 0.05 Hz		
	Overload Capability	≤ 125% : 10 minute ; ≤ 150% : 1 minute ; >150% : 1 second		
	Display	10" color touch screen		
Interface	Standard	RS232 x 1, Parallel port x 4, USB type A x 2, USB type B x 1, MODBUS x 1, Smart slot x 1, REPO x 1, EPO x 1, Input dry contact x 4, Output dry contact x 6, External battery temperature dry contact x 4, External switch/breaker status dry contact x 4, BMS (RJ45) x 1, Ethernet x 1		
	Optional	Relay I/O card, Battery cabinet temperature sensor cable		
Conformance	Safety	CE		
Efficiency	AC-AC Mode	Up to 96.5%		
	ECO Mode	99%		
Battery	Nominal Voltage	±240 Vdc		
	Charge Voltage	±272V (adjustable from 204V to 312V)		
	Protection of Battery Deep Discharge	Yes		
Environment	Operating Temperature	0 ~ 40°C		
	Relative Humidity	0 ~ 90% (non-condensing)		
	Audible Noise (at one meter)	< 75 dB	< 80 dB	< 85 dB
	IP Protection	IP20		
Others	Parallel Redundancy and Expansion	Module and system redundancy ; Maximum 8 units		
	Emergency Power Off	Remote (default) and local (optional)		
	Battery Start	Yes		
Physical	Dimensions (W x D x H)	600 x 1100 x 2000 mm		1200 x 1100 x 2000 mm
	Weight : UPS System (without power modules)	311 kg	317 kg	605 kg
	Weight : 50kW Power Module (optional)	36 kg		

\* The power module's power rating is adjustable to either 50kVA or 55.6kVA via touch panel.

\*\* When input vTHD is less than 1%.

All specifications are subject to change without prior notice.



2007~ 2008 Forbes Asia's Fabulous 50



2009 Frost & Sullivan Green Excellence Award for Corporate Leadership



Delta's Manufacturing System Certified by ISO 9001 and ISO 14001 Standards



IECQ Certificate of Hazardous Substance Process Management



## Europe

### Czech Republic

Delta Energy Systems  
(Czech Republic), spol.s r.o.  
Perucka 2482/7, 120 00 Praha 2,  
Czech Republic  
T +420 272 019 330  
E ups.czech.republic@deltaww.com

### Finland

Delta Solutions (Finland) Oy  
P.O. Box 63, Juvan teollisuuskatu 15, FIN-  
02921 Espoo, Finland  
T +358 9 84966 0  
E ups.finland@deltaww.com

### France

Delta Electronics (France) S.A.  
ZI du bois Chaland 2, 15 rue des Pyrénées,  
Lisses, 91056 Evry Cedex, France  
T +33 1 69 77 82 60  
E ups.france@deltaww.com

### Germany

Delta Energy Systems (Germany) GmbH  
Coesterweg 45, 59494 Soest, Germany  
T +49 2921 987 0  
E ups.germany@deltaww.com

### The Netherlands - EMEA Headquarters

Delta Electronics (Netherlands) BV  
Zandsteen 15, 2132MZ Hoofddorp,  
The Netherlands  
T +31 (0) 20 800 39 00  
E ups.netherlands@deltaww.com

### Poland

Delta Electronics (Poland) Sp. z o.o.  
23 Poleczki Str., 02-822 Warszawa,  
Poland  
T +48 22 335 26 00  
E ups.poland@deltaww.com

### Russia

Delta Energy Systems LLC  
Vereyskaya Plaza II, office 112, Vereyskaya  
str.17, 121357 Moscow, Russia  
T +7 495 644 3240  
E ups.russia@deltaww.com

### Slovak Republic

Delta Electronics (Slovakia) s.r.o.  
Botanicka 25/A, SK - 841 04 Bratislava,  
Slovakia  
T +421 2 6541 1258  
E ups.slovakia@deltaww.com

### Switzerland

Delta Electronics (Switzerland) AG  
Freiburgstrasse 251, 3018 Bern-Bümpliz,  
Switzerland  
T +41 31 998 53 11  
E ups.switzerland@deltaww.com

### Spain

Delta Electronics Solutions (Spain) SLU.  
Ctra. de Villaverde a Vallecas, 265 1º Dcha Ed.  
Hormigueras, 28031 - Madrid, Spain  
T +34 91223 7420  
E ups.spain@deltaww.com

### Turkey

Delta Greentech Electronic San. Ltd.  
Serifali Mevkii Barboros Bulvari Soylesi Sok No  
19 Y.Dudullu-Umraniye/Istanbul, Turkey  
T +90 216 499 9910  
E ups.turkey@deltaww.com

### United Kingdom

Delta Electronics Europe Ltd.  
1 Redwood Court, Peel Park, Campus, East  
Kilbride, G74 5PF, United Kingdom  
T +44 1355 588 888  
E ups.united.kingdom@deltaww.com

## Middle-East & Africa

### South Africa

Delta Energy Systems MEA (Switzerland) AG  
South Africa Representative Office  
Unit 305B, Lougardia Building, Cnr  
Embankment and Hendrik Verwoerd Drive,  
Centurion, 0157, South Africa  
T +27 12 663 2714  
E ups.south.africa@deltaww.com

### United Arab Emirates

Delta Energy Systems (Switzerland) AG  
Dubai Representative Office  
P.O. Box 185668  
Gate 7, 3rd Floor, Hamarain Centre, Dubai  
T +971 425 99 55 3  
E info.middle-east@deltaww.com

## Americas

### Brazil

Delta Greentech (Brasil) S/A  
Rua Itapeva, Nº 26 - 3º andar  
01332 000 - São Paulo - SP  
T +55 11 3530 8658  
E ups.brazil@deltaww.com

### The United States

Delta Electronics (Americas) Ltd.  
46101 Fremont Blvd.  
Fremont, CA 94538  
T +1 510 344 2157  
E ups.na@deltaww.com

## Asia Pacific

### Australia

Delta Energy Systems Australia Pty Ltd.  
Unit 20-21, 45 Normanby Road, Notting  
Hill VIC 3168, Australia  
T +61 3 9543 3720  
E ups.australia@deltaww.com  
**Sydney office:**  
Level 3 / 67-69 Epping Rd, North Ryde, NSW 2113

### China

Delta GreenTech (China) Co., Ltd.  
238 Minxia Road, Pudong, Shanghai, 201209  
P.R.C  
T +86 21 5863 5678 / +86 21 5863 9595  
E ups.china@deltaww.com

### India

Delta Power Solutions (India) Pvt. Ltd.  
Plot No. 43, Sector-35, HSIIDC,  
Gurgaon-122001, Haryana, India  
T +91 124 4874 900  
E ups.india@deltaww.com

### Indonesia

Wisma Aldiron 1st Floor, Suite 140, Jl. Jend.  
Gatot Subroto Kav. 72, Jakarta 12780,  
Indonesia  
E ups.indonesia@deltaww.com

### South Korea

Delta Electronics (Korea), Inc.  
1511, Byucksan Digital Valley 6-cha, Gasan-  
dong, Geumcheon-gu, Seoul, Korea 153-704  
T +82 2 515 5303  
E ups.south.korea@deltaww.com

### Malaysia

C-05-08, LEVEL 05, BLOCK C, SKYPARK  
One City, Jalan USJ 25/1  
47650 Subang Jaya  
Selangor Darul Ehsan, Malaysia  
E ups.malaysia@deltaww.com

### Philippines

Unit 1001 Richmond Plaza, San Miguel Ave.,  
Ortigas Centre, Pasig City, Philippines  
E ups.philippines@deltaww.com

### Singapore

Delta Energy Systems (Singapore) Pte Ltd.  
4 Kaki Bukit Ave 1, #05-04, Singapore  
417939  
T +65 6747 5155  
E ups.singapore@deltaww.com

### Taiwan

Delta Electronics Inc.  
39 Section 2, Huandong Road,  
Shanhua Township  
Tainan County 74144, Taiwan  
T +886 6 505 6565  
E ups.taiwan@deltaww.com

### Thailand

Delta Electronics (Thailand) Public Co., Ltd.  
909 Soi 9, Moo 4, E.P.Z., Bangpoo  
Industrial Estate, Tambon Prakasa,  
Amphur Muang-samutprakarn,  
Samutprakarn Province 10280, Thailand  
T +662 709-2800  
E ups.thailand@deltaww.com

### Vietnam

3rd floor, RIC Building, 51 Hoang Viet, Tan Binh,  
Ho Chi Minh City Vietnam  
E ups.vietnam@deltaww.com



# Delta UPS Solutions

Uninterruptible Power Supply

[www.deltaww.com](http://www.deltaww.com) | [www.deltapowersolutions.com](http://www.deltapowersolutions.com)

The power behind competitiveness



# About Delta Group

## Leading expert in power management and thermal management solutions

Delta, founded in 1971, is a global leader in switching power supplies and thermal management products with a thriving portfolio of smart energy-saving systems and solutions in the fields of industrial automation, building automation, telecom power, data center infrastructure, EV charging, renewable energy, energy storage and display, to nurture the development of smart manufacturing and sustainable cities. As a world-class corporate citizen guided by its mission statement, "To provide innovative, clean and energy-efficient solutions for a better tomorrow," Delta leverages its core competence in high-efficiency power electronics and its CSR-embedded business model to address key environmental issues, such as climate change. Delta serves customers through its sales offices, R&D centers and manufacturing facilities spread over close to 200 locations across 5 continents.

**World's No. 1** in Switching Power Supplies, DC Brushless Fans and Telecom Power Systems

**171** sales offices and **45** manufacturing facilities worldwide

**8%** of annual sales revenues invested in R&D with over **9,000** engineers in **74** R&D centers worldwide

Awarded **10,119+** patents and received **47** internationally recognized design awards including iF, Reddot, and the Taiwan Excellence awards.

## Worldwide No. 1 supplier of merchant power supplies

The Total Merchant Power Supply Market 2020 Revenue

Ranking	Company Name	Sales (M/USD)
1	Delta Electronics	\$ 5,636
2	Schneider Electric	\$ 3,500
3	Sungrow Power Supply	\$ 2,715

Source: Micro-Tech Consultants, 2020

## CSR Honors and Awards

Member of  
**Dow Jones Sustainability Indices**  
Powered by the S&P Global CSA

---

2011 – 2020  
DJSI - World Index  
2018-2020 Industry Leader

**CDP**  
ENVIRONMENTAL LEADERSHIP  
**A LIST 2020**  
**CLIMATE**

---

2020  
Climate Change  
Leadership Level

**CDP**  
ENVIRONMENTAL LEADERSHIP  
**A LIST 2020**  
**WATER**

---

2020  
Water Security  
Leadership Level

**Sustainability Award**  
Gold Class 2021  
**S&P Global**

---

2021  
Sustainability Award  
Gold Class

# Global Footprint

	Asia-Pacific	Americas	EMEA	Total
Sales Offices	100	26	45	171
Plant Sites	38	4	3	45
R&D Centers	50	10	14	74



More information about Delta Group can be found at [www.deltaww.com](http://www.deltaww.com) or [www.deltapowersolutions.com](http://www.deltapowersolutions.com)



# Data Center Solution Offering

Delta's InfraSuite offers a comprehensive, modular and highly integrated portfolio to support the creation of high-performance data centers. As a global leader in thermal and power management solutions, Delta has further strengthened its leading position in data center infrastructure with a complete offering of AC or DC power, cooling systems, monitoring platforms from micro and modular to containerized solutions.

## Our Service and Capability

- Provides total data center life cycle services, including consulting, design, simulation, implementation and after service.
- Designs and builds data centers per customer requirements using optimal solutions.
- Offers comprehensive power supply, power distribution, cooling system, modular racks and DCIM solutions for implementation anywhere.

	<ul style="list-style-type: none"> <li>• Generator</li> <li>• Switch Gear</li> <li>• MV/LV Transfer Switch</li> <li>• Large UPS</li> <li>• Modular UPS</li> <li>• Rack level UPS</li> <li>• 12 / 48VDC System</li> <li>• HDVC System</li> <li>• STS/ rSTS</li> <li>• PDU/ rPDU</li> <li>• Busway</li> </ul>
	<ul style="list-style-type: none"> <li>• Cooling Tower</li> <li>• Chiller</li> <li>• RowCool</li> <li>• Rear Door</li> <li>• Fan Wall</li> <li>• Hot Aisle</li> <li>• Containment System</li> </ul>
	<ul style="list-style-type: none"> <li>• DCIM</li> <li>• Building Automation System</li> <li>• Surveillance</li> <li>• Video Wall</li> <li>• Lighting</li> </ul>
	<ul style="list-style-type: none"> <li>• OCP Rack</li> <li>• Rack</li> <li>• Switch</li> <li>• DCI Router</li> </ul>

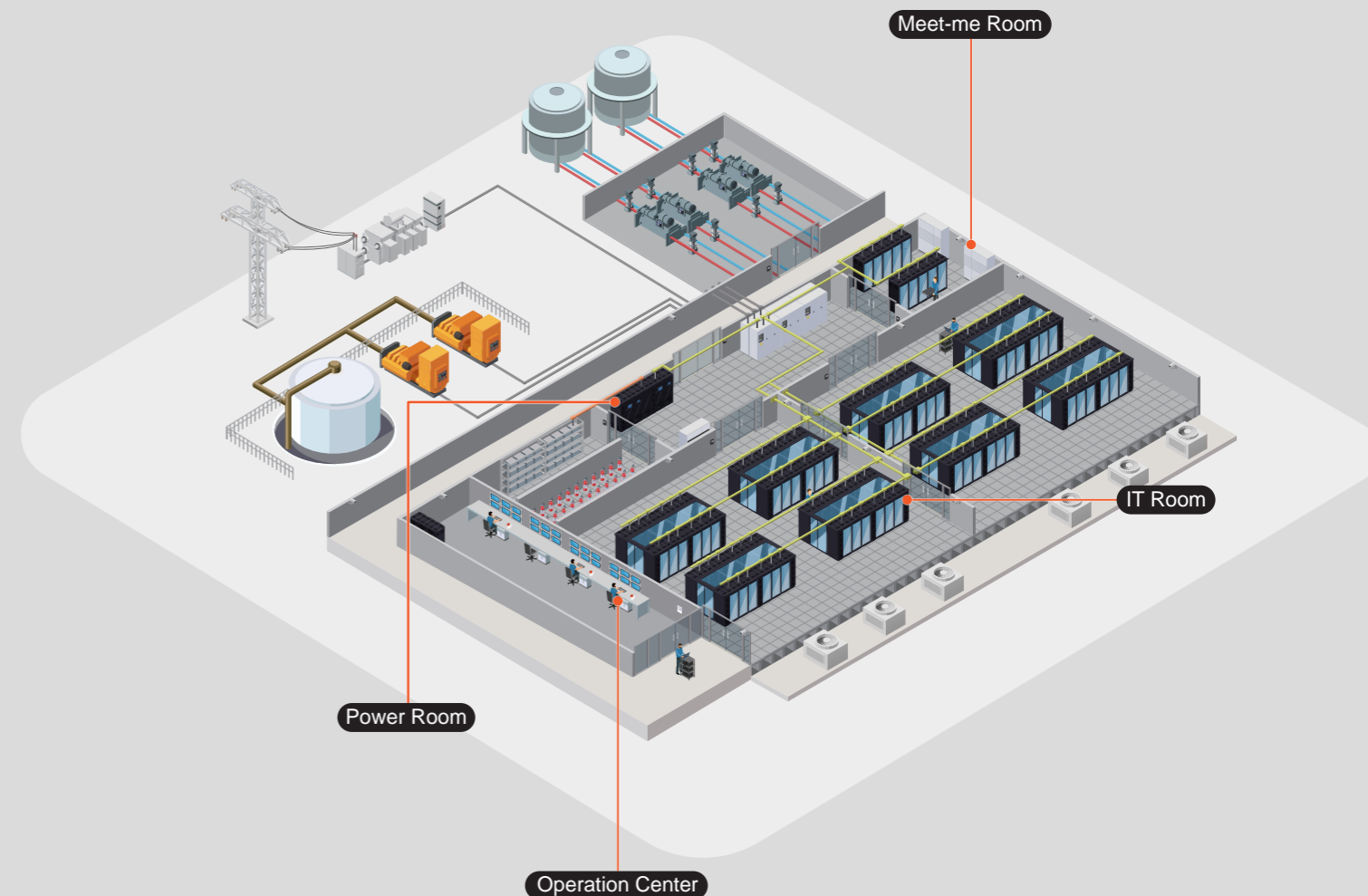

# Delta UPS

Our clients are most concerned about power issues such as power failure, power sag, power surge, under voltage or over voltage, frequency variation, harmonic distortion and line noise. Delta Electronics emphasizes the areas of redundant power supply, voltage regulation, equipment protection and adjustment and has designed and developed three UPS product families - Amplon, Ultron and Modulon. Their power range, applications and the equipment they protect are listed below:

Product Family	Power	Topology	Applications
Agilon	Under 1.5kVA	Single-Phase UPS	PC and Peripherals
Amplon	1kVA or higher	Single-Phase UPS	Server and Network Equipment
Ultron	10kVA or higher	Three-Phase On-Line UPS	Data Center and Industrial Equipment
Modulon	20kVA or higher	Three-Phase Modular On-Line UPS	Modular unit expansion and redundant power supply can be achieved within a single rack.

Delta UPS systems feature the following:

- Leading AC-AC Efficiency
- Fully redundant design and configuration
- High input and output power factors
- Easy expansion without additional hardware
- Support for seamless operations at low level of TCO (Total Cost of Ownership)



# Product Application Matrix

	Agilon		Amplon				
	VX Series 0.6-1.5 kVA (line-interactive)	MX Series 1.1-3 kVA (line-interactive)	N Series 1-3 kVA (on-line)	N Series 6-10 kVA (on-line)	R Series 1-3 kVA (on-line)	RT Series 1-3 kVA (on-line)	RT Series 5-20 kVA (on-line)
Configuration 1:1	O	O	O	O	O	O	O
Configuration 3:1							O (15/20 kVA)
Configuration 3:3							O (15/20 kVA)
Rack mountable		O			O	O	O
Tower	O	O	O	O	O	O	O
Isolation transformer							
Battery ' I	I	I	I, E	E	E	I, E	E
Home and office *	O	O	O			O	
Small enterprise, IT and medical **		O	O	O	O	O	O
Medium enterprise, telecom, IT, media ***				O			O
Heavy industry, telecom, IT, Industrial ****							

	Ultron				Modulon	
	HPH Series 20-200 kVA (on-line)	NT Series 20-500 kVA (on-line)	DPS Series 300-1200 kVA (on-line)	DPM Series 250-1250 kVA (on-line)	DPH Series 25-200 kVA (on-line)	DPH Series 50-500 kVA (on-line)
Configuration 1:1						
Configuration 3:1		O				
Configuration 3:3	O	O	O	O	O	O
Rack mountable						
Stand-alone	O	O	O	O		
Modular					O	O
Isolation transformer		O				
Battery ' I (BN/B), E	I (BN/B), E	E	E	E	I (75K), E	E
Home and office *						
Small enterprise, IT and medical **	O	O	O		O	O
Medium enterprise, telecom, IT, media ***	O	O	O	O	O	O
Heavy industry, telecom, IT, Industrial ****	O	O	O	O		

'I': internal battery, E: external battery

\* PCs, laptops, modems, printers, WiFi and audio equipment

\*\* Computers, servers, networking, medical control and diagnostics, education, banking, industrial automation

\*\*\* Telecom base stations, data centers, backbone networks, broadcasting, projection systems

\*\*\*\* Telecom centers, data centers, medical equipment at hospitals, government use, automatic control, oil, gas and power utilities, industrial equipment, automation and control

## Known for Our Quality

### Delta's manufacturing across the globe

The Delta Group's operations are global in scale with 45 manufacturing facilities in Taiwan, China, Thailand, India, Mexico, Brazil and Slovakia. We also have 74 R&D centers across the globe and 171 sales offices on all 5 continents.



### Accredited laboratory

Delta's outstanding product design capability comes from our R&D team and its various precision measurement instruments. Our R&D centers utilize diverse advanced equipment and programs including CAD to facilitate circuit simulation, mechanical design, and PCB layout. Delta has nine well-equipped laboratories to conduct environment-related substance analysis, precision measurement, failure analysis, soldering techniques, electromagnetic compatibility and interference tests, material chemical analysis, quality engineering, safety tests, and more. In addition, we also have laboratories with controlled temperature and humidity to perform numerous reliability tests.



ORT (Ongoing reliability test)



EMC / EMI (electromagnetic compatibility & interference)



Acoustic test



Pulse lightning discharge

## Why Delta UPS?



### Quality

- Delta's large-scale production follows comprehensive quality management to do things right the first time and deliver the best quality
- All manufacturing sites are certified with ISO 9001 and ISO 14001 and conform to the highest quality control in terms of product development and production to achieve customer satisfaction.
- With six laboratories accredited by the China National Accreditation Service for Conformity Assessment (CNAS) all of our products go through the tightest checks.



### Performance

- Wide input voltage range reduces the chance of battery use and extends battery life
- High input power factor increases utilization of utilities and reduces total cost
- High output power factor provides more real power to critical loads
- Higher efficiency lowers operating costs
- Lower harmonic distortion saves on upstream investment
- Compact design saves more space for critical equipment



### Service

- Service line is available on work days to answer your questions
- Customer-needs-oriented, available with comprehensive and professional service and technical support

# Data Center Footprints

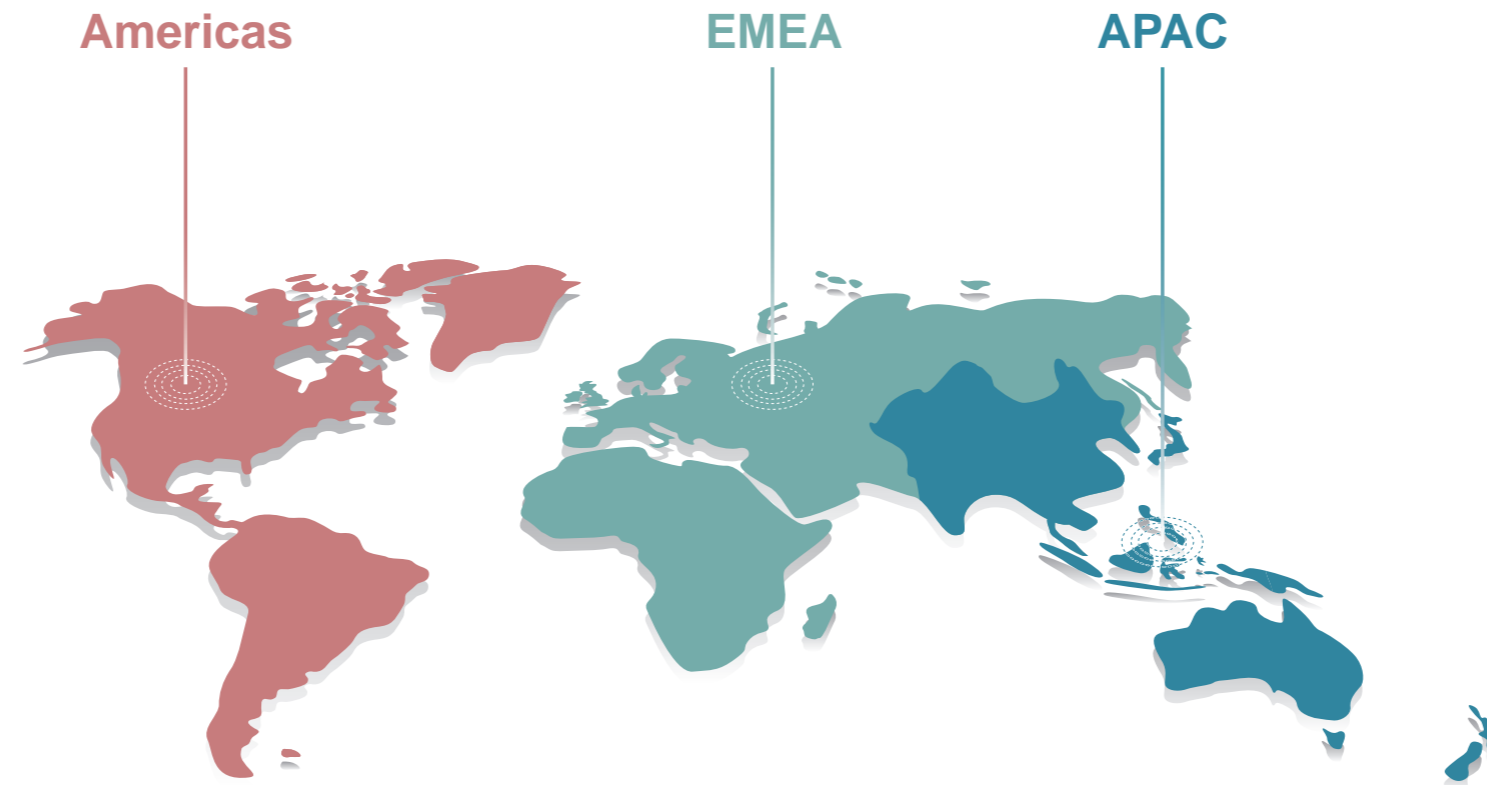

**U.S**  
Power Protection for the "Grab & Go" Shopping Store 1.8 MW



**Russia**  
Government Data Center 1.6 MW



**China**  
Lin Kong Port Data Center 26 MW  
Internet Data Center 5 MW



**Vietnam**  
HTC-ITC, TCCF TIER III-Certified Data Center 750 kW



**Brazil**  
Power Protection for the Largest Private Sector Bank 1.6 MW



**Spain**  
Atos Data Center 200 kW



**Taiwan**  
National Data Center 5.5 MW  
Formosa Plastics Data Center 750kW



**India**  
NetMagic Data Center 22 MW  
Yotta Corp, Colocation 1 MW



**South Africa**  
University Data Center 150 kW



**Netherland**  
Bytesnet, Colocation 6 MW



**Thailand**  
Telecom Data Center 5.2 MW



**Australia**  
Prefabricated Modular Data Center 100MW+

# Delta UPS – Agilon Family

## VX Series, Line-interactive 600/1000/1500VA



The Agilon VX series line-interactive UPS designed with microprocessor control offers reliable and cost-effective power protection for PCs, monitors, POS, and other sensitive electronics used in home offices and small businesses. The integrated Automatic Voltage Regulation (AVR) ensures all electronics are receiving stable power while providing higher availability. The Agilon VX series' LCD display, auto-shutdown software and other superior features make these units perfect for your data protection.

### Reliability

- The integrated AVR (Automatic Voltage Regulation) stabilizes the output voltage for better power quality
- Excellent microprocessor control enables accurate detection of power frequency for higher reliability
- Wide input voltage range allows the UPS to work in harsh electrical environments and reduces battery discharging time
- Batteries are automatically recharged even when the UPS is in off mode and the UPS can start without mains (Cold-Start)
- UPS is able to restart automatically while utility power is recovering
- Surge protection defends your critical load against damage

### Convenience

- Several standard IEC 320 output sockets simplify the connectivity to computer and IT peripherals
- Compact size saves more space for critical equipment

### Manageability

- Standard USB communication port enhances monitoring and manageability
- Touch screen LCD for a clear display of UPS information (Only applicable for LCD models)
- Advanced UPS management software provides remote shutdown and control

#### Applicable Sectors

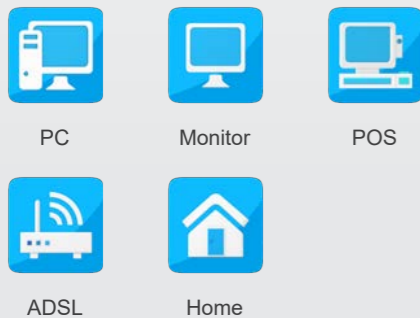

## Technical Specifications

Model		VX-600VA	VX-1000VA	VX-1500VA
<b>Power Rating</b>	VA	600	1000	1500
	W	360	600	900
<b>Input</b>	Nominal Voltage	230Vac		
	Voltage Range	170~280Vac (full load)		
	Frequency	45~65Hz		
<b>Output</b>	Voltage	230Vac ± 10% (Battery mode)		
	Frequency	50/60Hz ± 1Hz		
	Waveform (Batt. Mode)	Simulated Sinewave		
	Receptacle	IEC 320 C13 x 4	IEC 320 C13 x 4	IEC 320 C13 x 4 (SEA model) IEC 320 C13 x 6 (EMEA model)
<b>Indicator</b>		LED (SEA model) LCD (EMEA model)	LCD	
	<b>Interfaces</b>	Standard	USB Port x 1	
<b>Conformance</b>	Safety	CE		
<b>Battery</b>	Battery Type & Number	12V/7Ah x 1	12V/7Ah x 2	12V/9Ah x 2
	Recharge Time	6~8 hours to 90%		
	Cold Start	Yes		
<b>Environment</b>	Operating Temperature	0~40°C		
	Altitude	0~1000m		
	Relative Humidity	0~95% (non-condensing)		
	Audible Noise	< 40dB		< 45dB
<b>Physical</b>	Dimensions (W x D x H)	101 x 279 x 142mm	130 x 320 x 182mm	130 x 320 x 182mm
	Net Weight	4.2kg (SEA model) 4.4kg (EMEA model)	8.2kg	9.7kg (SEA model) 10.4kg (EMEA model)

The above specifications are for SEA and EMEA models.

All specifications are subject to change without prior notice.



# Delta UPS – Amplon Family

## MX Series, Line-interactive 1.1/2/3 kVA



The Amplon MX line-interactive UPS provides pure sine-wave quality compatibility for versatile application to protect devices and prevent small-and-medium businesses from power failure and voltage variations all in a small footprint. The Amplon MX series features enhanced output power factor 0.9, and AVR efficiency up to 96.5%, resulting in a greater power supply for critical loads at significantly less operating cost.

### Availability

- Microprocessor-based line interactive design for fast response to power disturbances
- Programmable load bank disconnects non-critical loads when a blackout occurs and reserves more battery power for critical loads
- Automatic voltage regulator (AVR) delivers stable output voltage during brownouts or over-voltages
- Wide input voltage range allows the UPS to work in harsh electrical environments
- Hot-swappable battery design protects equipment during battery replacement

### Flexibility

- Supports both rack and tower installation
- Excellent management through a user-friendly graphical and easy-shift LCD display to suit different installation formats
- Supports multiple communication interfaces, including USB port, RS-232, Mini Slot, Surge Protection, REPO for enhanced monitoring and manageability

### Low Total Cost of Ownership

- Output power factor is up to 0.9 to provide more real power to critical loads
- High efficiency normal mode reaches 98% and 98.5% for 3kVA
- Wide input range and protection against over voltage prolongs battery life

#### Applicable Sectors

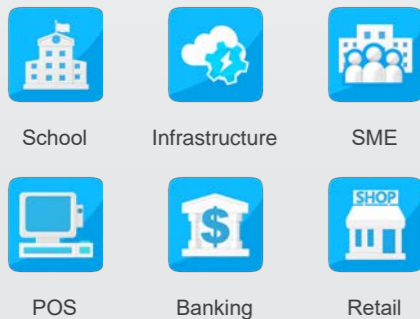

## Technical Specifications

Model		MX-1.1K	MX-2K	MX-3K
<b>Power Rating</b>	kVA	1.1	2	3
	kW	0.99	1.8	2.7
<b>Input</b>	Voltage Range	200Vac: 150-234Vac / 208Vac: 156-243Vac / 220Vac: 162-268Vac 230Vac: 170-280Vac / 240Vac: 177-290Vac		
	Nominal Frequency	50/60Hz (Auto-Detection)		
	Connection	IEC C14	IEC C20	
	Phase	Single phase with ground		
<b>Output</b>	Voltage	200/208/220/230/240Vac		
	Harmonic Distortion	Linear load (full load) ≤ 2%; Non-linear load (full load) ≤ 5%		
	Voltage Regulation	±1.5% (Batt. Mode)		
	Frequency (Battery Mode)	50/60Hz ± 1Hz		
	Overload Capability	103~120%: 5 minutes (1 minute @ Battery mode); 120~150%: 10 seconds; > 150%: UPS shutdown immediately		
	Connection	IEC C13 (4+4)	IEC C13 (4+4)	IEC C13 (4+4) IEC C19 (1)
	Current Crest Ratio	3:1		
Waveform (Battery Mode)	Pure Sinewave			
<b>Interface</b>	Standard	RS-232 Port x 1, USB Port x 1, MINI Slot x 1, Surge Protection, REPO		
<b>Efficiency</b>	Normal Mode	98%		98.5%
	AVR Mode	95.5%	96.5%	
<b>Battery</b>	Battery Type	12V/9Ah Sealed lead-acid battery		
	Numbers	2	4	6
	Recharge Time	4 hours recover to 90% capacity		
<b>Environment</b>	Operating Temperature	0~40°C		
	Relative Humidity	20~90% RH (non-condensing)		
	Noise Level	< 45dBA	< 45dBA @ Normal mode, < 55dBA @ Battery mode	
<b>Physical</b>	Dimensions (W x D x H)	438 x 410 x 88mm	438 x 510 x 88mm	438 x 630 x 88mm
	Net Weight	14.1kg	21.3kg	32.1kg

All specifications are subject to change without prior notice.



# Delta UPS – Amplon Family

## N Series, Single Phase 1/2/3 kVA



The Amplon N series is a true online double-conversion UPS that can provide your critical equipment with reliable, stable sine wave power. It features significant advantages, including an output power factor of 0.9 and up to 93% AC-AC efficiency for greater energy savings. The Amplon N series provides a safe power supply guaranteed for mission critical applications such as work stations, POS, ATMs, servers, and more.

### Availability

- True online double-conversion topology and zero transfer time to battery ensure high reliability
- Advanced DSP (Digital Signal Processor) controller for fast computation capability and a simplified control circuit for enhanced stability
- Wide input voltage range allows the UPS to work in harsh electrical environments
- Generator compatibility ensures continuous and reliable power

### Green with Low TCO

- High input power factor (> 0.99) and low input harmonic distortion (iTHD < 3%) save upstream investment
- Output power factor up to 0.9 presents a stronger load capacity
- AC-AC efficiency up to 93% and high efficiency of 91% at 50% load results in marked energy cost savings
- Compact design saves more space for critical equipment

### Intelligent Management

- Excellent local communications through LCD display
- Intelligent battery management maximizes battery performance and sustains battery life
- Mini slot and USB port enhance monitoring and manageability

#### Applicable Sectors

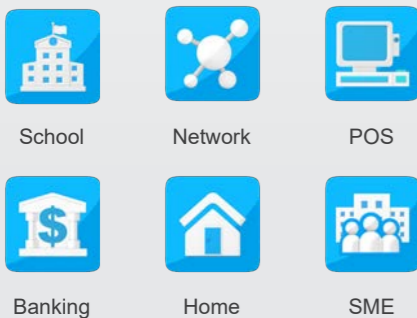

## Technical Specifications

Model		N-1K	N-2K	N-3K
<b>Power Rating</b>	kVA	1	2	3
	kW	0.9	1.8	2.7
<b>Input</b>	Nominal Voltage	220/230/240Vac		
	Voltage Range	175~280Vac (full load); 80~175Vac (50~100% load)		
	Current Harmonic Distortion	< 3%		
	Power Factor	> 0.99 (full load)		
	Frequency	50/60Hz ± 10Hz		
<b>Output</b>	Voltage	220/230/240Vac		
	Voltage Harmonic Distortion	< 3% (linear load)		
	Power Factor	0.9		
	Frequency	50/60Hz ± 0.05Hz		
	Overload Capability	< 105%: continuous; 105~125%: 1 minute; 125~150%: 30 seconds		
	Receptacle	IEC C13 x 4	IEC C13 x 6, C19 x 1	
	Crest Factor	3:1		
<b>Display</b>		LCD panel		
<b>Interfaces</b>		MINI Slot x 1, USB Port x 1		
<b>Conformance</b>	Safety & EMC	CE, RCM, EN62040-1, EN62040-2 Category C2		
<b>Efficiency</b>	AC-AC	91%	Up to 93%	
<b>Battery</b>	Battery Voltage	24Vdc	48Vdc	72Vdc
	Typical Backup Time	4.5 minutes (full load); 13 minutes (half load)		
	Recharge Time	3 hours to 90%		
	Charge Current	1.5A		
<b>Environment</b>	Operating Temperature	0~40°C		
	Relative Humidity	0~95% (no condensing)		
	Audible Noise	< 43dB	< 48dB	
<b>Physical</b>	Dimensions (Wx Dx H)	145 x 320 x 225mm	190 x 390 x 325mm	
	Weight	9kg	18.6kg	24.4kg

The above specifications are for SEA and EMEA models.

All specifications are subject to change without prior notice.



# Delta UPS – Amplon Family

## N Series, Single Phase 6/10 kVA



The Amplon N series 6-10kVA UPS is a single-phase on-line UPS with pioneering technology that provides output power factor up to unity and AC-AC efficiency to a maximum 95%. Its remarkably compact dimensions reserve more room for critical equipment such as workstations, POSs, ATMs, office appliances, small server rooms, and production equipment. The Amplon N series superior features include a N+X parallel redundancy function and variable fan speed control to guarantee high system availability and best Total Cost of Ownership (TCO).

### The Most Compact Design and Best TCO

- The smallest dimensions in its class saves significant space for more critical equipment
- A pioneer in unity power factor (kVA=kW) to maximize power availability
- The highest AC-AC efficiency up to 95% and efficiency of 98% in ECO mode for exceptional energy cost savings
- Automatic speed regulation function with multi-stage fan speed control to maximize system efficiency, significantly reduce audible noise, and prolong the service life of the fans

### High Availability

- True online double-conversion topology and zero transfer time to battery to ensure high reliability
- Parallel configuration for expansion and N+X redundancy up to 4 units
- Advanced DSP (Digital Signal Processor) controller for fast computation capabilities and a simplified control circuit for enhanced stability
- Generator compatibility to ensure continuous and reliable power

### Intelligent Management

- Excellent local communications through user-friendly LCD display and LED indicators
- Intelligent battery management to maximize battery performance and extend battery life
- Various types of communication interfaces for monitoring and manageability

#### Applicable Sectors

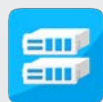

Server



Network



Security



Telecom



Banking

## Technical Specifications

Model		N-6K	N-10K
Power Rating	kVA	6	10
	kW	6	10
Input	Nominal Voltage	200/208/220/230/240Vac	
	Voltage Range	200/208 (de-rating to 90%): 100~280Vac* 220/230/240: 100~280Vac**	
	Current Harmonic Distortion	< 3%	
	Power Factor	> 0.99 (full load)	
	Frequency	40~70Hz	
	Output	Nominal Voltage	200/208/220/230/240Vac
Voltage Harmonic Distortion		< 2% (linear load)	
Power Factor		1	
Frequency		50/60Hz ± 0.05Hz	
Overload Capability		< 105%: continuous; 105~125%: 2 minutes; 125~150%: 30 seconds	
Crest factor		3:1	
Display		LED indicators and LCD display	
Interfaces		REPO x 1, RS-232 Port x1, USB Port x1, Parallel Port x 2, Smart Slot x 1	
Efficiency	AC-AC	Up to 95%	
	ECO Mode	Up to 98%	
Battery	Battery Voltage	192~264Vdc adjustable	
	Charge Current	1.5~8A selectable	
Environment	Operating Altitude	1000 meters (without de-rating)	
	Operating Temperature	0~40°C (at 100% load) 45~55°C (de-rating to 80%)	
	Storage Temperature	-15~50°C	
	Relative Humidity	5~95% (non-condensing)	
	Audible Noise	< 50dB	
	Physical	Dimensions (W x D x H)	190 x 390 x 325mm
Weight		10.1kg	12.7kg

\* Linear de-rating between 40~90% load at 100~175Vac.

\*\* Linear de-rating between 40~100% load at 100~194Vac.

The above specifications are for SEA and EMEA models.

All specifications are subject to change without prior notice.



# Delta UPS – Amplon Family

## R Series, Single Phase 1/2/3 kVA (Extended Runtime Model)



Delta's Amplon R series is an online double-conversion rack-mountable UPS providing consistent sine-wave power to your critical equipment and reliable protection for IT equipment and data centers. The R series offers an output power factor of 0.9 and a best-in-class AC-AC efficiency of up to 93% for greater energy savings. The Amplon R series leads the industry in combining compact size, availability, flexibility, and low total cost of ownership.

### Availability

- True online double-conversion topology provides zero transfer time to ensure maximum protection of the equipment
- Watch-dog design of the DSP (Digital Signal Processor) increases reliability
- Cold-start capability provides temporary battery power when the utility power is out
- Operating temperature tolerance up to 50°C ensures critical loads' continuity
- The Maintenance Bypass Box offers load continuity during battery replacement or other upgrades

### Flexibility

- Compact dimensions meet the needs of different rack cabinets
- Convertible rack and tower configuration in 2U size cabinet
- Excellent local communications through rotatable LCD display
- Intelligent management software connectivity via RS232, mini slot or USB port

### Low Total Cost of Ownership

- Wide input voltage range reduces the chance of using the battery and extends battery life
- Intelligent battery management sustains battery life and performance
- High output power factor 0.9 provides more real power to critical loads
- High input power factor (pf > 0.99) and low harmonic distortion (iTHD < 3%) save upstream investment
- Up to 93% AC-AC efficiency and 96% efficiency in ECO mode results in marked energy cost savings
- Fan speed control by load level and room temperature optimizes performance

#### Applicable Sectors



## Technical Specifications

Model		R-1K	R-2K	R-3K
<b>Power Rating</b>	kVA	1	2	3
	kW	0.9	1.8	2.7
<b>Input</b>	Nominal Voltage	200*/208*/220/230/240Vac		
	Voltage Range	175~280Vac (full load); 80~175Vac (50~100% load)		
	Current Harmonic Distortion	< 3%		
	Power Factor	> 0.99 (full load)		
	Frequency	50/60Hz ± 10Hz		
<b>Output</b>	Voltage	200*/208*/220/230/240Vac		
	Voltage Harmonic Distortion	< 3% (linear load)		
	Voltage Regulation	±1% (linear load)		
	Power Factor	0.9		
	Frequency	50/60Hz ± 0.05Hz		
	Overload Capability	< 105%: Continuous; 105~125%: 1 minute; 125~150%: 30 seconds		
	Receptacle	IEC C13 x 4	IEC C13 x 6, IEC C19 x 1	IEC C13 x 6, IEC C19 x 1 (SEA model) IEC C13 x 6, Terminal x 1 (EMEA model)
<b>Display</b>	LCD display and LED indicators			
<b>Interfaces</b>	Standard	Mini Slot x 1, RS-232 Port x 1, USB Port x 1		
<b>Conformance</b>	Safety	CE, RCM, TISI, EAC		
<b>Efficiency</b>	AC-AC	91%	Up to 93%	
	ECO Mode	95%	Up to 96%	
<b>Battery</b>	Battery Voltage	24Vdc	48Vdc	72Vdc
	Charge Current	4A (up to 8A with optional inbuilt charger)		
<b>Environment</b>	Operating Temperature	0~50°C***		
	Relative Humidity	5~95% (non-condensing)		
	Audible Noise**	< 40dB	< 43dB	
<b>Physical</b>	Dimensions (Wx Dx H)	440 x 335 x 88mm	440 x 430 x 88mm	
	Weight	5.3kg	9.0kg	9.1kg

\* When the UPS is de-rated to 90% of its capacity.

\*\* If the UPS is running at < 75% load and in room temperature.

\*\*\* When the operating temperature is at 40~50°C, the UPS will be de-rated to 80% of its capacity.

The above specifications are for SEA and EMEA models.

All specifications are subject to change without prior notice.



# Delta UPS – Amplon Family



## RT Series, Single Phase 1/2/3 kVA

The Amplon RT 1-3kVA series is an online double-conversion UPS providing consistent sine-wave power to your critical equipment. It supports personal computers, networks, servers, VoIP and telecommunications. RT 1-3kVA series features an output power factor of 0.9 and best-in-class AC-AC efficiency up to 94% resulting in greater energy savings. Optional external battery pack can be connected for longer backup time to keep your applications safe and running smoothly at all times.

### Availability

- True online double-conversion topology and zero transfer time to battery ensure high reliability
- Watch-dog design of DSP (Digital Signal Processor) increases reliability
- Cold-start capability provides temporary battery power when the utility power is out
- Fan failure detection alerts users to failed fans
- Hot swappable batteries ensure continuous operation even when batteries are being replaced
- Optional external battery pack for easy scaling of longer backup time

### Green & Low TCO

- High output power factor 0.9 provides more real power to critical loads
- High input power factor (pf > 0.99) and low harmonic distortion (iTHD < 5%) save upstream investment
- Up to 94% AC-AC efficiency and 97% efficiency in ECO mode result in marked energy cost savings
- Wide input voltage range reduces the chance of using the battery and extends battery life
- Intelligent battery management sustains battery life and performance
- Fan speed control by load level maximizes efficiency and reduces audible noise

### Flexibility

- Load segment control allows less-critical loads to be disconnected during blackouts and saves battery runtime for important loads
- Convertible rack and tower configuration in 2U size cabinet
- Excellent local communications through rotatable LCD display
- Intelligent management software connectivity via RS232 or USB port

## Technical Specifications

Model		RT-1K	RT-2K	RT-3K
<b>Power Rating</b>	kVA	1	2	3
	kW	0.9	1.8	2.7
<b>Input</b>	Nominal Voltage	200*/208*/220/230/240Vac		
	Voltage Range	175~280Vac (full load); 120~175Vac (70~100% load)		
	Current Harmonic Distortion	< 5%		
	Power Factor	> 0.99 (full load)		
	Frequency	40~70Hz		
<b>Output</b>	Voltage	200*/208*/220/230/240Vac		
	Voltage Harmonic Distortion	< 2% (linear load)		
	Voltage Regulation	±1% (linear load)		
	Power Factor	0.9		
	Frequency	50/60Hz ± 0.05Hz		
	Overload Capability	< 105%: continuous; 105~125%: 1 minute; 125~150%: 15 seconds		
	Receptacle	IEC C13 x 6	IEC C13 x 6, IEC C19 x 1	
<b>Display</b>	LCD display and LED indicators			
<b>Interfaces</b>	SMART Slot x 1, RS-232 Port x 1, USB Port x 1, REPO x 1			
<b>Comformance</b>	CE, TISI, RCM, EAC			
<b>Efficiency</b>	Online Mode	90%	Up to 94%	
	ECO Mode	96%	Up to 97%	
<b>Battery</b>	Battery Voltage	24Vdc	48Vdc	72Vdc
	Typical Backup Time**	6.5min	7.5min	
	Charge Current	1.5A	2A	
	Recharge Time	3 hours to 90%		
<b>Environment</b>	Operating Temperature	0~50°C***		
	Relative Humidity	5~95% (non-condensing)		
	Audible Noise	< 40dB	< 43dB	< 46dB
<b>Physical</b>	Dimensions (W x D x H):			
	UPS	440 x 335 x 89mm	440 x 432 x 89mm	440 x 610 x 89mm
	External Battery Pack	440 x 335 x 89mm	440 x 432 x 89mm	440 x 610 x 89mm
	Weight:			
	UPS	12kg	18kg	28kg
External Battery Pack	15kg	27kg	44kg	

\* When the UPS is de-rated to 90% of its capacity.

\*\* When the total load reaches 75%.

\*\*\* 40~50°C with 80% de-rating

All specifications are subject to change without prior notice.



### Applicable Sectors



Server



Telecom



Industrial



VoIP



Storage



Network



Medical

# Delta UPS – Amplon Family

## RT Series

Single Phase, 5/6/8/10 kVA

Three Phase, 10/15/20 kVA



The Amplon RT Series 5-20kVA is an online double-conversion UPS that provides best-in-class designs in a compact 2U size, with high power density, system efficiency, and versatile configurations to fulfill customers' requirements. RT Series 5-20kVA UPS is the first in the market that offers standard Li-ion external battery cabinets, which deliver better power density and sustainability. Along with the parallel capacity of up to four units, the new series is the ideal small power UPS for mission-critical applications, such as servers, data centers, telecommunications, and manufacturing.

### Availability & Flexibility

- True online double-conversion topology and zero transfer time to battery provides 24/7 full-time protection
- Programmable load bank disconnects non-critical loads when a blackout occurs and reserves more battery power for critical loads
- Up to four units parallel capacity allows redundancy and load expansion
- Hot swappable batteries ensure continuous operation even when batteries are being replaced
- VRLA and Li-ion External Battery Cabinet (EBC) are available for scalable runtime
- The Power Distribution Box (PDB) and Maintenance Bypass Breaker (MBB) are optional respectively for easy configuration and easy UPS replacement.
- The rRPP (Rack Remote Power Panel), which can be integrated with standard server racks, simplifies power output distribution and power monitoring
- Common battery configuration is supported in UPS parallel mode to save installation space and additional battery costs

### Efficiency & Reliability

- Unity output power factor guarantees no de-rating with loads and provides permanent 100% kW
- Best-in-class AC-AC efficiency of up to 96.5% and 99% in ECO mode lowers energy costs
- Automatic fan speed control maximizes system efficiency and significantly reduces audible noise and prolongs battery life
- Fan failure detection sends early warnings to facilitate predictive maintenance of UPS

## Technical Specifications

Model		RT-5K	RT-6K	RT-8K	RT-10K	RT-10K3P	RT-15K3P	RT-20K3P
<b>Power Rating</b>	kVA	5	6	8	10	10	15	20
	kW	5	6	8	10	10	15	20
<b>Input</b>	Voltage Range	100~280Vac (Single phase, 2-wire + G) 100~175Vac with linear de-rating 50~100%				138~485Vac (Three phase, 4-wire + G) 138~305Vac with linear de-rating 40~100%		
	iTHD	< 3%						
	Power Factor	> 0.99 (full load)						
	Frequency	40~70Hz						
	Input Connection	Input terminal x 1				Input terminal x 1, Bypass Input terminal x 1		
<b>Output</b>	Voltage	200/208/220/230/240Vac (Single phase)				380/400/415Vac (Three phase), or 220/230/240Vac (Single phase)		
	Voltage Harmonic Distortion	≤ 2% (linear load)						
	Power Factor	Unity						
	Frequency	50/60Hz ± 0.05Hz						
	Overload Capability	≤ 105%: continuous; 106~125%: 5 minutes; 126~150%: 1 minute; > 150%: 500ms				≤ 105%: continuous; 106~125%: 2 minutes; 126~150%: 30 seconds; > 150%: 200ms		
<b>Receptacle</b>	Standard Runtime Model	C13 x 6, C19 x 2, Terminal x 1 Load bank: C19 x 1		C13 x 6, C19 x 4, Terminal x 1 Load bank: C19 x 1		Terminal x 1		
	Extended Runtime Model	Terminal x 1 Load bank: Terminal x 1						
<b>Display</b>	Graphical and multi-lingual LCD							
<b>Interfaces</b>	MINI Slot x 1, Parallel Port** x 2, USB Port x 1, RS232 Port*** x 1, RS485 Port x 1, REPO/ROO Port x 1, Dry Contact x 4							
<b>Conformance</b>	CE, UL/cUL, TISI, RCM, EAC							
<b>Efficiency</b>	AC-AC	Up to 95.5%				Up to 96%	Up to 96.5%	
	ECO Mode	Up to 99%				99%		
<b>Battery Voltage</b>	Standard Runtime Model	192Vdc		240Vdc		144Vdc*; 192~264Vdc		±144Vdc*; ±192~±264Vdc
	Extended Runtime Model	144Vdc*; 192~264Vdc						
<b>Charger Current</b>	Standard Runtime Model	1A (default)		1.5A (default)		Up to 8A		
	Extended Runtime Model	Up to 8A						
<b>Typical Backup Time (VRLA Battery)</b>	Standard Runtime Model	75% load	7.5min	5.5min	9min	6min		Depending on different configurations required by customers
		Full load	5min	3min	5min	3.5min		
	Extended Runtime Model	Depending on different configurations required by customers						
<b>Environment</b>	Operating Temperature	0~55°C****						
	Relative Humidity	5~95% (non-condensing)						
	Audible Noise	48dB		50dB		54dB		
<b>Dimensions (W x D x H)</b>	Standard Runtime Model	440 x 665 x 176mm		440 x 750 x 218mm		440 x 649 x 88.2mm		440 x 760 x 88.2mm
	Extended Runtime Model	440 x 430 x 88.2mm		440 x 565 x 88.2mm				
<b>Weight</b>	Standard Runtime Model	54kg		85.5kg		16.6kg		22kg
	Extended Runtime Model	10.9kg		15.2kg		22.5kg		

\* De-rating to 70% load  
 \*\* Only applicable to RT 5-10kVA Extended Runtime Model and RT 15/20kVA  
 \*\*\* Not applicable to RT 15/20kVA  
 \*\*\*\* When the operating temperature is at 40~55°C, the UPS will be de-rated to 75% of its capacity

All specifications are subject to change without prior notice.



### Applicable Sectors

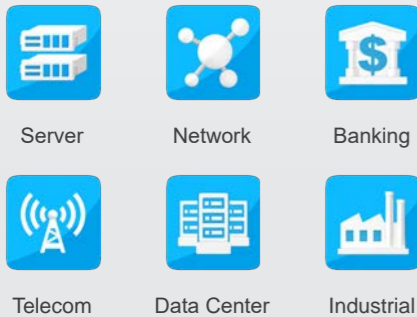

# Delta UPS – Ultron Family

## HPH Series, Three Phase 20-120 kVA



The Ultron HPH is a true online double-conversion UPS offering the best-in-class combination of maximum available power, unbeatable energy efficiency and superior power performance for small data centers and other mission critical applications. With fully rated power (kVA=kW), the Ultron HPH provides maximum available power without de-rating the UPS. Thanks to the three level IGBT topology for both PFC (power factor correction) and inverter, the Ultron HPH features up to 96% AC-AC efficiency. Delta's advanced digital PFC control also contributes low iTHD < 3% and high input power factor > 0.99 resulting in significant TCO (Total Cost of Ownership) savings. Facilitating increased availability and power performance, the Ultron HPH is an ideal solution for protecting your mission critical operations.

### Best-in-Class Power Performance and Efficiency

- Fully rated power (kVA=kW) for maximum power availability
- Leading AC-AC efficiency up to 96% saves energy costs
- Low harmonic pollution (iTHD < 3%) and high input power factor (> 0.99) reduce upstream investment costs

### Assured Reliability

- Wide input voltage range allows the UPS to operate in harsh electrical environments and extends battery life
- DSP based technology enables reduction in the number of electronic components to lower failure rate
- Redundant auxiliary power and fan design\* enhance system reliability

### Greater Flexibility

- A wide choice of configurations, such as N+X redundancy and hot stand-by
- Adjustable charging current and charging voltage meet different battery configuration requirements
- Flexible battery configuration optimizes battery investment

### Superior Serviceability and Management

- Front-door battery replacement with hot-swappable battery tray design supports easy and quick replacement without turning the unit off (HPH-B / BN)
- Swappable interior architecture and front access servicing enables quick and easy maintenance\*
- Multi-connectivity interface supports remote UPS monitoring and management

\* Applies to 60-120kVA models

## Technical Specifications

Model		HPH-20K HPH-20K-BN/B	HPH-30K HPH-30K-BN/B	HPH-40K HPH-40K-BN/B	HPH-60K	HPH-80K	HPH-100K	HPH-120K
<b>Power Rating</b>	kVA	20	30	40	60	80	100	120
	kW	20	30	40	60	80	100	120
<b>Input</b>	Nominal Voltage	380/220Vac; 400/230Vac; 415/240Vac (3 phase, 4-wire + G)						
	Voltage Range	300~477Vac (full load); 228~300Vac (70~100% load) 332~477Vac (full load); 228~332Vac (63~100% load)						
	Current Harmonic Distortion	< 3%						
	Power Factor	> 0.99 (full load)						
	Frequency	40~70Hz						
<b>Output</b>	Voltage	380/220Vac; 400/230Vac; 415/240Vac (3 phase, 4-wire + G)						
	Voltage Harmonic Distortion	< 1.5% (linear load)				< 2% (linear load)		
	Voltage Regulation	±1%						
	Power Factor	1						
	Frequency	50/60Hz ± 0.05Hz						
	Overload Capability	≤ 105%: continuous; 106~≤125%: 10 minutes; 126~≤150%: 1 minute; > 150%: 1 second						
<b>Interfaces</b>	SMART Slot x 1, MINI Slot x 1, Parallel Port x 2, RS232 Port x 1, REPO Port x 1, Charger Detection Port x 1, Input Dry Contact x 2, Output Dry Contact x 6, USB Port x 1*							
<b>Conformance</b>	Safety	CE, RCM						
<b>Efficiency</b>	AC-AC	Up to 96%				> 96% (HPH 40-120K peak efficiency is tested by TÜV)		
	ECO Mode	Up to 99%						
<b>Battery</b>	Battery Voltage	240Vdc						
	Type	Support SMF/VRLA/Tubular/Ni-Cd						
	Quantity	32~50pcs				32~46pcs***		
	Charge Current (Max.) Built-in	5A	9A		10A	15A	20A	
	Additional Charger Board (optional)					20A	40A	
	Typical Backup Time**	15min	10min	9.5min	N/A			
<b>Environment</b>	Operating Temperature	0~40°C						
	Relative Humidity	5~95% (non-condensing)						
	Audible Noise	< 55dB	< 60dB	< 65dB				
<b>Others</b>	Parallel Redundancy	Up to 4 units						
	Emergency Power Off	Local and remote						
	Maintenance Bypass Switch	Yes						
<b>Physical</b>	Dimensions (W x D x H)	380 x 800 x 800mm			520 x 800 x 1175mm	520 x 800 x 1760mm		
	Weight	66.5kg	86.06kg	86.5kg	186.5kg	191kg	312kg	
<b>Physical (BN/B)</b>	Dimensions (W x D x H)	490 x 830 x 1400mm			N/A			
	Weight (with battery)	365kg	385kg		N/A			
	Weight (without battery)	131kg	162kg		N/A			

HPH-B: UPS integrated battery model has batteries inside

HPH-BN: UPS integrated battery model has no batteries inside

\* Applied for models HPH-60/80/100/120K

\*\* At 70% load with internal battery strings

\*\*\* UPS needs de-rating for battery quantity 32-36 pcs. Please contact authorized Delta personnel

All specifications are subject to change without prior notice.



**TÜVRheinland®**  
Precisely Right.

Delta Ultron HPH 40~120kVA  
Efficiency is tested by TÜV

### Applicable Sectors

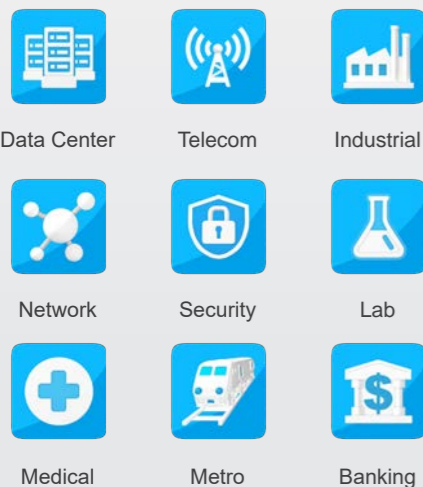

# Delta UPS – Ultron Family

## HPH Series, Three Phase 160/200 kVA



The brand-new Ultron HPH series 160-200kVA is a true online double-conversion UPS offering the best-in-class combination of power performance and efficiency for medium data centers, pan-IT, and other mission critical applications. Thanks to Delta's R&D expertise and excellent engineering capabilities, the Ultron HPH features up to 96.5% AC-AC efficiency, low iTHD < 3%, and high input power factor > 0.99 resulting in significant total cost of ownership (TCO) savings. Highlights of the highly reliable Ultron HPH series UPS design include key component redundancy and proactive battery health detection. With its combination of superior availability and power performance, the Ultron HPH 160-200kVA is the top choice for power protection of sustainable medium business operations.

### Best-in-class Power Performance and Efficiency

- High AC-AC efficiency of up to 96.5% and ECO mode to 99% for significant energy cost savings
- Low harmonic pollution (iTHD < 3%) and high input power factor (> 0.99) reduces upstream investment costs

### Assured Availability

- Optional redundant controller supports dual CAN bus and ring connection for high system availability
- Proactive battery aging detection for high reliability
- Easy event log check via touch panel and firmware upgrade via USB port

### Greater Flexibility

- Parallel expansion and redundancy up to 8 units, 1.6MVA of total power capacity
- Flexible battery configuration 30~46 pieces optimizes battery investment
- Supports either top or bottom cable entry in the single cabinet. The unique fixed symmetric terminal design avoids cable bending issues to enhance cable reliability

### Superior Manageability

- User-friendly 10" colored LCD with touch panel enables easy local UPS management
- Environment information such as security, water, fire and temperature can be integrated into the UPS for easy monitoring via the LCD of the UPS
- If the UPS is equipped with Delta's battery management system, the battery information can be integrated into the UPS and monitored via LCD

## Technical Specifications

Model		HPH-160K	HPH-200K
Power Rating	kVA	160*	200
	kW	150	200
Input	Nominal Voltage	220/380Vac; 230/400Vac; 240/415Vac (3-phase, 4-wire + G)	
	Voltage Range	305~478Vac (full load); 228~478Vac (70% load)	
	Current Harmonic Distortion	≤ 3%**	
	Frequency	40~70Hz	
Output	Voltage	220/380Vac; 230/400Vac; 240/415Vac (3-phase, 4-wire + G)	
	Voltage Harmonic Distortion	≤ 0.5% (linear load)	
	Frequency	50/60Hz	
	Frequency Regulation	±0.05Hz (battery mode)	
	Overload Capability	≤125%: 10 minutes; ≤150%: 1 minute	
Display		10" color touch screen	
Interface	Standard	External battery temperature detection x 4, External switch/breaker status dry contact x 4, Output dry contact x 6, Input dry contact x 4, Parallel port x 2, USB Port (Type A x 2; Type B x 1), RS232 Port x 1, Modbus Port x 1, BMS (RJ45) x 1, Ethernet x 1, SNMP Slot x 1, REPO Port x 1	
	Optional	Relay I/O card, Battery cabinet temperature sensor cable	
Conformance	Safety	CE, RCM	
Efficiency	AC-AC	Up to 96.5%	
	ECO Mode	99%	
Battery	Nominal Voltage	±240Vdc	
	Charge Voltage	±272Vdc (default, ±180Vdc to ±276Vdc configurable)	
	Battery Number Configuration	30~46pcs (default: 40pcs)	
Environment	Operating Altitude	1000 meters (without derating)	
	Operating Temperature	0~40°C	
	Audible Noise	< 70dB	
	Relative Humidity	0~95% (non-condensing)	
Others	Parallel Redundancy and Expansion	Maximum 8 units	
	Remote Emergency Power Off	Yes	
	Battery Start	Yes	
Physical	Dimensions (W x D x H)	600 x 1100 x 1600mm	
	Weight	339kg	376kg









\* The power rating is adjustable from default 160kVA to 150kVA via touch panel

\*\* When input vTHD is less than 1%

All specifications are subject to change without prior notice.



### Applicable Sectors

 Data Center	 Telecom	 Industrial
 Network	 Security	 Lab
 Medical	 Metro	 Banking

# Delta UPS – Ultron Family

## HPH Gen.2 Series, Three Phase 20/30/40 kVA



The latest HPH Gen.2 20-40kVA UPS offers a compact footprint with full rated output PF at 40 degree to optimize the UPS sizing. The 0.99 input PF and iTHD<2% ensure maximum upstream source compatibility. Low total cost of ownership is achieved by >96% efficiency, energy recycle mode, wider battery quantity configuration and inbuilt 15A charger. In addition, it provides a user-friendly interface touch panel, manual protection devices and caster wheels for easy deployment, installation and operation. All these features provide the ideal solution for various small and medium-sized data centers and critical power backups.

### Easy Deployment and Maintenance with Compact Design

- Inbuilt casters for easy move-in, positioning and maintenance
- Inbuilt input / bypass input / output / maintenance bypass breakers for completed distribution panel
- Slim design and smallest footprint (40kW in 0.15m2) to reduce wasted space

### Low Total Cost of Ownership

- Wide battery quantity configuration (30-46pcs) optimizes the battery solution
- High AC-AC efficiency over 96% and ECO mode to 99% resulting in marked energy cost savings
- Low input harmonic distortion (iTHD < 2%) is highly compatible with upstream of UPS power without additional filter or over sizing generator

### High Manageability and Flexibility

- User-friendly 5" color touch screen enables easy local UPS management
- Optional SNMP IPv6 and Modbus communication cards for remote monitoring
- Inbuilt 15A charger for long backup solution without additional cost
- Optional IP42 kit for harsh environment applications
- Front access and easy battery replacement for inbuilt battery models

#### Applicable Sectors

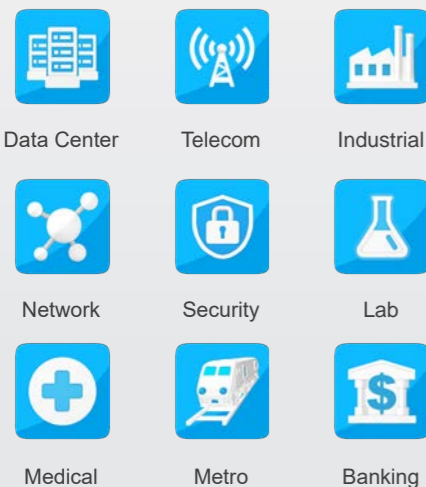

## Technical Specifications

Model		HPH-20K/20KB*/20KB-N*	HPH-30K/30KB*/30KB-N*	HPH-40K/40KB*/40KB-N*
<b>Power Rating</b>	kVA	20	30	40
	kW	20	30	40
<b>Input</b>	Nominal Voltage	220/380Vac; 230/400Vac; 240/415Vac (3-phase, 4-wire + G)		
	Voltage Range	305~478Vac (full load); 228~478Vac (70% load)		
	Current Harmonic Distortion**	≤ 2.5%	≤ 2%	
	Power Factor	> 0.99		
	Frequency	40~70Hz		
<b>Output</b>	Voltage	220/380Vac; 230/400Vac; 240/415Vac (3-phase, 4-wire + G)		
	Voltage Harmonic Distortion	≤ 1.5% (linear load); ≤ 4% (non-linear load)		
	Voltage Regulation	±1% (static)		
	Frequency	50/60Hz		
	Overload Capacity	≤ 105%: continuously; > 105~≤ 110%: 60 minutes; > 110%~≤ 125%: 10 minutes; > 125%~≤ 150%: 1 minute; > 150%: 1 second		
<b>Display</b>		5" color touch screen		
<b>Interfaces</b>	Standard	External battery temperature detection x1, Output dry contact x4, Input dry contact x2, Parallel port x2, USB Port x1, RS232 Port x1, REPO Port x1, Mini Slot x2		
<b>Conformance</b>	Safety	CE, RCM (IEC62040-1, IEC62040-2 Class C2)		
<b>Efficiency</b>	AC-AC	> 96% (Peak efficiency)		
	ECO Mode	99%		
<b>Battery</b>	Nominal Voltage	±240Vdc (default, ±180Vdc to ±276Vdc configurable)		
	Charge Voltage	±272Vdc (adjustable from 204Vdc to 312Vdc)		
	Maximum Inbuilt Charger Current	15A		
	Discharge Time***	20min	14min	9.5min
<b>Environment</b>	Operating Temperature	0~40°C		
	Relative Humidity	0~95% (non-condensing)		
	Audible Noise (at one meter)	< 50dB	< 56dB	
	IP Protection	IP20 (Standard); IP42 (Optional for long backup model)		
<b>Others</b>	Parallel Redundancy and Expansion	Up to 4 units		
	Battery Start	Yes		
<b>Physical</b>	Dimensions (W x D x H)	240 x 630 x 650mm		
	Weight	44kg	50kg	
<b>Physical (HPH-B/B-N)</b>	Dimensions (W x D x H)	470 x 780 x 1200mm		
	Weight (B: with battery)	334kg	340kg	
	Weight (B-N: without battery)	94kg	100kg	

\* HPH-B: UPS integrated battery model has batteries inside;  
 \* HPH-B-N: UPS integrated battery model has no batteries inside.  
 \*\* When input harmonic distortion is less than 1%.  
 \*\*\* UPS at 70% load with internal battery strings.

All specifications are subject to change without prior notice.



# Delta UPS – Ultron Family

## NT Series, Three Phase 20-500 kVA



The Ultron NT series is a three phase UPS featuring customized I/P-O/P ratings for various applications. With N+X parallel redundancy or expansion, it guarantees high availability and reliability for your critical loads.

The Ultron NT series offers continued seamless protection for your business even under 100% unbalanced loading conditions. Its economy mode improves efficiency and saves operating cost.

### Availability

- Available from 20 to 4,000 kVA (8 x 500 kVA in parallel)
- Parallel redundancy without requiring extra hardware to increase reliability
- Optional harmonic filter and 12-pulse rectifier
- Redundant auxiliary power and control circuit ensures higher reliability
- Inbuilt maintenance and static bypass switch









### Flexibility

- Multi-language LCD display and LED status indicators
- RS232, RS485 and six programmable dry contact outputs
- Compatible with generator installation and unbalanced loads
- Optional external battery cabinet for longer backup time

### Low Total Cost Of Ownership

- Parallel expansion as your business grows and consequently saves initial investment
- Wide input voltage range extends battery lifetime
- Economy mode saves energy and operating cost
- Common battery installation saves initial investment

#### Applicable Sectors

 Data Center	 Telecom	 Industrial
 Network	 Security	 Lab
 Medical	 Metro	 Banking

## Technical Specifications

Model		NT-	20K	30K	40K	50K	60K	80K	100K	120K	160K	200K	260K	320K	400K	500K
<b>Power Rating</b>	kVA		20	30	40	50	60	80	100	120	160	200	260	320	400	500
	kW		16	24	32	40	48	64	80	96	128	160	208	256	320	400
<b>Input</b>	Nominal Voltage	208/120Vac; 380/220Vac; 400/230Vac; 415/240Vac; 480/277Vac (3 phase, 4-wire + G)														
	Voltage Range	305-499Vac														
	Current Harmonic Distortion	< 3% (with optional power filter, full load)														
	Frequency	45-65Hz														
<b>Output</b>	Voltage	208/120Vac; 380/220Vac; 400/230Vac; 415/240Vac; 480/277Vac (3 phase, 4-wire + G) 220/230/240Vac (1 phase)*														
	Voltage Harmonic Distortion	≤ 3% (linear load)														
	Voltage Regulation	±1% (static)														
	Power Factor	0.8														
	Frequency	50/60Hz ± 0.01% (internal oscillator); ±1% (synchronized)														
	Overload Capability	≤ 110%: 60 minutes; 110~125%: 10 minutes; 126~150%: 1 minute														
	Standard	RS232 x 1, RS485 x 2, SMART slot x 1, Output dry contact x 6														
<b>Efficiency</b>	AC-AC	90%	91%		91.5%		92%		92.5%			93%				
	ECO Mode	> 97%	> 97.5%													
<b>Environment</b>	Operating Temperature	0~40°C														
	Relative Humidity	0~95% (non-condensing)														
	IP Protection	IP20														
	Audible Noise (at 1.5 meters)	≤ 60dB			≤ 65dB						≤ 68dB		≤ 72dB			≤ 77dB
<b>Others</b>	Parallel Redundancy	Up to 8 units														
	Emergency Power Off	Local and remote														
	Event Log	500 records														
	Input Harmonic Improvement	Optional harmonic filter and 12-pulse rectifier														
<b>Physical</b>	Dimensions (W x D x H)	600 x 800 x 1400mm					800 x 830 x 1700mm		1200 x 830 x 1700mm		1600 x 995 x 1950mm		1900** x 995 x 1950mm		3110**	
	Weight (kg)	365	365	425	460	506	525	700	745	1050	1085	1680	1720	1920	3110**	

\* Single phase output voltage: 220/230/240Vac is only for 20~40kVA models.

\*\* 500kVA model is assembled into two cabinets: Inverter (width=1100mm, 1760kg) and Rectifier (width=800mm, 1350kg).

All specifications are subject to change without prior notice.



# Delta UPS – Ultron Family

## DPS Series, Three Phase 300-1200 kVA



Delta's superior Ultron DPS series 300 - 1200kVA UPS supports unity output power factor to deliver up to 9.6 MW power capacity to meet the demands for large data centers and colocations. The Ultron DPS series guarantees the highest level of system reliability by supporting self-detection of key components with pre-warning function, multi-layered redundancy design, and complete power rating coverage. Along with optional battery management software, the DPS series enables users to achieve predictive maintenance and minimize system downtime, while lowering the total cost of ownership (TCO).

### Ultimate Availability

- Supports up to 9.6 MW power capacity with the parallel redundancy and expansion up to 8 units
- Redundant components and dual CAN bus ensures system availability
- Proactive detection of key component status for early diagnosis on UPS malfunction
- Intelligent battery health diagnosis enables better battery maintenance and replacement
- Advanced event analysis, including 10,000 event logs, waveform capturing and key parameters recording, to detect UPS abnormality and ensure higher availability

### Excellent Performance

- The industry's leading power density and smallest footprint with the design of both top/bottom cable entry and inbuilt switches
- Unity output power factor guarantees no-rating and provides 100% kW
- AC-AC efficiency of up to 96.5% and 99% in ECO mode resulting in marked energy cost savings
- Supports both VRLA and environment-friendly Li-ion batteries

### Sophisticated Manageability and Flexibility

- Environment information, such as security, water, fire, and temperature can be integrated and monitored via the LCD panel of the UPS
- If the UPS is equipped with an external battery management system, the battery information can be integrated and monitored via the LCD panel of the UPS
- Flexible battery quantity of 30-46 pcs achieves optimal battery investment

## Technical Specifications

Model		DPS-300K	DPS-400K	DPS-500K	DPS-600K	DPS-800K	DPS-1000K	DPS-1200K
<b>Power Rating</b>	kVA	300	400	500	600	800	1000	1200
	kW	300	400	500	600	800	1000	1200
<b>Input</b>	Nominal Voltage	220/380Vac; 230/400Vac; 240/415Vac (3-phase, 4-wire + G)						
	Voltage Range	176/304~276/478Vac (full load)						
	Current Harmonic Distortion	< 3% (with Full Linear Load); < 5% (with Full Non-linear Load)						
	Power Factor	> 0.99						
	Frequency Range	40~70Hz						
<b>Output</b>	Voltage	220/380Vac, 230/400Vac, 240/415Vac (3-phase, 4-wire + G)						
	Voltage Harmonic Distortion	< 1.5% (Linear Load); < 5% (Non-linear Load)						
	Voltage Regulation	±1 (static); ±5 (dynamic)						
	Power Factor	1						
	Frequency	50/60Hz (Auto-Selectable)						
	Overload Capability	≤ 125%: 10 minutes; ≤ 150%: 1 minute; >150%: 1 second						
<b>Display</b>		10" Color Touch Panel						
<b>Interface</b>	Standard	RS232, Parallel port, USB, Modbus RS485, Input dry contact, Output dry contact, SNMP card inbuilt in touch screen						
	Optional	Relay I/O card, Battery cabinet temperature sensor cable						
<b>Conformance</b>	Safety	CE						
<b>Efficiency</b>	AC-AC	Up to 96.5%						
	ECO Mode	99%						
<b>Battery</b>	Type	VRLA, LiB						
	Charge Current	90A	120A	150A	180A	240A	300A	360A
	Battery Quantity	30~46pcs						
<b>Environment</b>	Operating Temperature	0~40°C						
	Relative Humidity	0~95% (non-condensing)						
	Audible Noise	< 80dB						
	IP Protection	IP20						
<b>Others</b>	Parallel Redundancy and Expansion	Maximum 8 units						
	Emergency Power Off	Remote and local						
<b>Physical</b>	Dimensions (W x D x H)	600*x 900 x 2000mm	1200*x 900 x 2000mm			1800 x 900 x 2000mm	2450 x 900 x 2000mm	
	Weight	515kg	700kg	811kg	970kg	1270kg	1850kg	2000kg

\* The width is for the cabinet which has four inbuilt switches.

\* For DPS-300K, only top cable entry is available

All specifications are subject to change without prior notice.



### Applicable Sectors

Data Center	Telecom	Industrial
Network	Medical	Metro
Banking	Infrastructure	Government
Education		

# Delta UPS – Modulon Family

## DPH Series, Three Phase 20 - 80/120 kVA



In this IT intensive world with heavy data traffic driven by cloud, 4G/5G and media streaming applications, IT managers are facing the challenges of increasing rack power density and limited data center space. Delta's innovative modular UPS technologies provide the answer to customers' demands for ultimate availability, excellent performance, and high efficiency. The brand-new Delta Modulon DPH series UPS 80/120 kVA achieves the industry's leading power density of 20kW per module in 2U height, offering the smallest footprint and best space utilization. The Modulon DPH Series UPS is the ideal modular power protection for all critical IT applications with its small package, flexibility and seamless integration.

### Excellent Power Performance

- The industry's leading power technology offers up to 120kW within all equipped breakers in 162.8 kW/m<sup>3</sup> which supports the top/bottom cable entry without additional cabinet to achieve the best utilization compared with its peers
- High AC-AC efficiency over 96% and ECO mode to 99% resulting in marked energy cost savings
- Green mode featuring a load aggregation function optimizes system efficiency

### Ultimate Availability

- Fully modularized design and hot-swappable key modules ensure Mean Time To Repair (MTTR) close to zero without downtime risk
- Redundant components and dual CAN bus delivers highest system availability and avoids single point of failure
- Key components aging pre-warning mechanism provides proactive reliability to minimize human error and reduce downtime risk (optional)

### High Manageability

- User-friendly 10" color touch screen enables easy local UPS management
- Environment information such as temperature, humidity and transmitting signals from environment sensors can be integrated into the UPS for easy monitoring via the LCD of the UPS
- If the UPS is equipped with an external battery management system, the battery information can be integrated into the UPS and monitored via the LCD of the UPS

## Technical Specifications









Model		DPH-80K	DPH-120K
<b>Power Rating</b>	kVA	20, 40, 60, 80	20, 40, 60, 80, 100, 120
	kW	20, 40, 60, 80	20, 40, 60, 80, 100, 120
	Power Module Quantity	Up to 4 units	Up to 6 units
<b>Input</b>	Nominal Voltage	220/380Vac; 230/400Vac; 240/415Vac (3-phase, 4-wire + G)	
	Voltage Range	305~478Vac (full load); 228~478Vac (70% load)	
	Current Harmonic Distortion	≤ 2%*	
	Power Factor	> 0.99	
	Frequency	50/60Hz	
<b>Output</b>	Voltage	220/380Vac; 230/400Vac; 240/415Vac (3-phase, 4-wire + G)	
	Voltage Harmonic Distortion	≤ 1% (linear load); ≤ 4% (non-linear load)	
	Voltage Regulation	±1% (static)	
	Frequency	50/60Hz	
	Overload Capability	≤ 125%: 10 minutes; ≤ 150%: 1 minute; >150%: 1 second	
<b>Display</b>		10" color touch screen	
<b>Interface</b>	Standard	External battery temperature detection x 4, External switch/breaker status dry contact x 4, Output dry contact x 6, Input dry contact x 4, Parallel port x 2, USB Port (Type A x 2; Type B x 1), RS232 Port x 1, Modbus Port x 1, BMS (RJ45) x 1, Ethernet x 1, SNMP Slot x 1, REPO Port x 1	
<b>Conformance</b>	Safety	CE (IEC62040-1, IEC62040-2 (C3: standard, C2: optional))	
<b>Efficiency</b>	AC-AC	> 96% (Peak efficiency)	
	ECO Mode	99%	
<b>Battery</b>	Nominal Voltage	±240Vdc (default, ±180Vdc to ±276Vdc configurable)	
	Charge Voltage	±272Vdc (adjustable from 204Vdc to 312Vdc)	
	Protection of Battery Deep Discharge	Yes	
<b>Environment</b>	Operating Temperature	0~40°C	
	Relative Humidity	0~95% (non-condensing)	
	Audible Noise (at one meter)	< 65dB	
	IP Protection	IP20	
<b>Others</b>	Parallel Redundancy and Expansion	Module and system redundancy ; Maximum 8units	
	Battery Start	Yes	
<b>Physical</b>	Dimensions (W x D x H)	600 x 850 x 1445mm	
	Weight:		
	UPS System (without power modules)	150kg	162kg
20kW Power Module (optional)	18kg		

\* When input voltage total harmonic distortion input is less than 1%.

All specifications are subject to change without prior notice.



### Applicable Sectors

 Data Center	 Telecom	 Industrial
 Network	 Security	 Lab
 Medical	 Metro	 Banking

# Delta UPS – Modulon Family

## DPH Series, Three Phase 25 - 75/150/200 kVA



The Modulon DPH supports ultimate availability for data center operations and provides the benefit of “pay as you go” without over-sizing the UPS. While achieving ultimate availability, the Modulon DPH does not compromise on power efficiency performance. When availability, efficiency and expanding according to business needs are essential, the Modulon DPH is the ideal UPS system to provide power protection and total cost of ownership (TCO) savings.

### Ultimate Availability

- Advanced fault tolerance design achieved by self redundancy guarantees operation continuity
- Self-synchronization of power and control modules for continuous on-line operation even in the event of control module failure avoids downtime caused by single point failure
- Hot-swappable key modules and components ensure Mean Time To Repair (MTTR) close to zero without downtime risk

### High Scalability

- Vertical expansion from 25kW to 75/150/200kW supporting N+X redundancy in a single rack enclosure reduces footprint
- Parallel expansion up to four units without requiring additional hardware
- Optional Rack-Mount Power Distribution Cabinet (rPDC) (applicable for 75/150kW models) has flexibility to arrange its UPS's output power feeding according to its connected critical loads
- Optional built-in battery modules (applicable for 75kW models) at maximum four units (four battery trays each)

### Excellent Power Performance and Efficiency

- Full rated power (kVA=kW) maximizes power availability
- High operating efficiency of 95% at 30% load and 96% from 50% load results in marked energy cost savings
- Low harmonic pollution (iTHD<3%) reduces upstream investment costs and meets demanding power requirements

### Easy Maintenance

- Built-in manual bypass features eliminate maintenance-related downtime
- Proactive detection of fan failure and switch fault for early diagnosis of UPS malfunction
- Plug and play modularity simplifies the maintenance process

## Technical Specifications

Model		DPH-75K	DPH-150K	DPH-200K
<b>Power Rating</b>	kVA	25, 50, 75	25, 50, 75, 100, 125, 150	25, 50, 75, 100, 125, 150, 175, 200
	kW	25, 50, 75	25, 50, 75, 100, 125, 150	25, 50, 75, 100, 125, 150, 175, 200
<b>Frame</b>	kW	75	150	200
	Power Module Quantity	3	6	8
<b>Input</b>	Nominal Voltage	380/220Vac; 400/230Vac; 415/240Vac (3 phase, 4-wire +G)		
	Voltage Range	305~477Vac (full load); 242~305Vac (55~100% load)		
	Current Harmonic Distortion	< 3%*		
	Power Factor	> 0.99		
	Frequency	50/60Hz**		
<b>Output</b>	Voltage	380/220Vac; 400/230Vac; 415/240Vac (3 phase, 4-wire +G)		
	Voltage Harmonic Distortion	≤ 2% (linear load)		
	Voltage Regulation	±1% (static)		
	Power Factor	1 (kVA=kW)		
	Frequency	50/60Hz ± 0.05Hz		
	Overload Capacity	≤ 125%: 10 minutes; ≤ 150%: 1 minute		
<b>Interface</b>	Standard	System communication port x 1, LCM port x 1, Parallel port x 2, Smart slot x 2, Output dry contact x 6, Input dry contact x 2, Battery dry contact x 2, REPO		
	Optional	Battery cabinet temperature sensor, SNMP IPv6 card, ModBus card, Relay I/O card		
<b>Conformance</b>	Safety & EMC	BSMI, CE		
<b>Efficiency</b>	AC-AC	96% (Tested by TÜV)		
	ECO Mode	99%		
<b>Environment</b>	Operating Temperature	0~40°C		
	Relative Humidity	0~95% (non-condensing)		
	Audible Noise (at one meter)	< 62dB		
	IP Protection	IP20		
<b>Others</b>	Parallel Redundancy and Expansion	Module and system redundancy; Maximum 4 units		
	Emergency Power Off	Local and remote		
	Battery Start	Yes		
	Event Log	3000 records		
	<b>Physical</b>	Dimensions (W x D x H)	600 x 1090 x 2000mm	
Weight:				
UPS System		310kg	320kg	350kg
25kW Power Module		32kg		
Rack-mount Power Distribution Cabinet		32kg		N/A
Battery Module		29.5kg	N/A	N/A
<b>Maximum Capacity</b>	Rack-mount Power Distribution Cabinet (rPDC)	1	2	N/A
	Breaker Module (for rPDC)	6	12	N/A
	Battery Module	4	N/A	N/A

\* When input vTHD is less than 1%.

\*\* Input frequency range can be adjusted up to 40Hz to 70Hz. Delta provides configuration service.

All specifications are subject to change without prior notice.



### Applicable Sectors

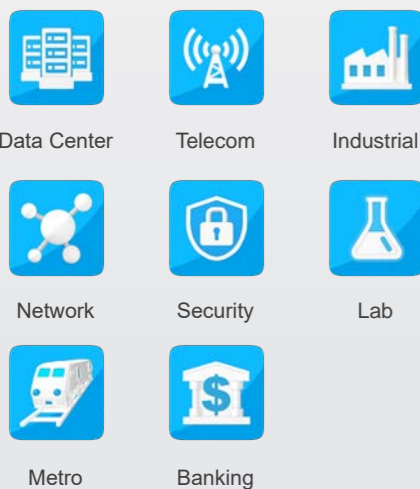

# Delta UPS – Modulon Family

## DPH Series, Three Phase 50 - 300/500/600 kVA



In this IT intensive world with heavy data traffic driven by cloud, 4G/5G and media streaming applications, IT managers are facing the challenges of increasing rack power density and limited data center space. Delta's innovative modular UPS technologies provide the answer to customers' demands for high power density, high power performance, and ultimate availability. The brand-new Delta Modulon DPH series UPS 50-300/500/600kVA achieves the industry's leading power density of 50kW per module, offering the smallest footprint and best space utilization. The Modulon DPH Series UPS is the ideal modular power protection for MW data centers to achieve total cost of ownership (TCO) optimization.

### Excellent Power Performance

- The industry's leading power density per module at 50kW in a 3U space, and the smallest footprint for 500kVA in a single rack and 600kVA in two racks, to achieve the best utilization compared with its peers
- High AC-AC efficiency up to 96.5% and ECO mode to 99% results in marked energy cost savings
- Green mode featuring a load aggregation function optimizes system efficiency

### Ultimate Availability

- Fully modularized design and hot-swappable key modules ensure Mean Time To Repair (MTTR) close to zero without downtime risk
- Redundant components and dual CAN bus delivers highest system availability and avoids single point of failure
- Modular UPS grows with your business by parallel expansion up to 8 units for 4.8MVA of total power capacity

### High Manageability

- User-friendly 10" color touch screen enables easy local UPS management
- Environment information such as security, water, fire, and temperature can be integrated into the UPS for easy monitoring via the LCD of the UPS
- If the UPS is equipped with an external battery management system, the battery information can be integrated into the UPS and monitored via the LCD of the UPS

#### Applicable Sectors

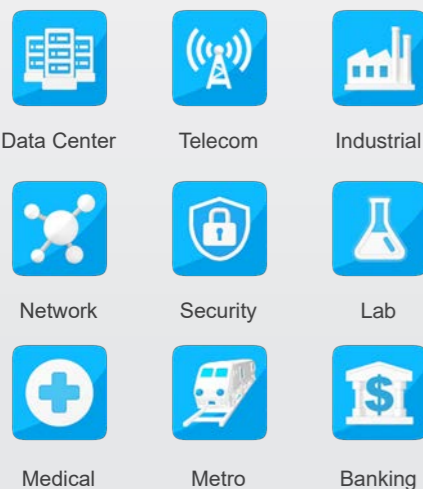

## Technical Specifications

Model		DPH-300K	DPH-500K	DPH-600K
<b>Power Rating</b>	kVA	100, 150, 200, 250, 300	300, 350, 400, 450, 500*	500, 550, 600
	kW	100, 150, 200, 250, 300	300, 350, 400, 450, 450	500, 550, 600
	Power Module Quantity	Up to 6 units	Up to 9 units	Up to 12 units
<b>Input</b>	Nominal Voltage	220/380Vac; 230/400Vac; 240/415Vac (3-phase, 4-wire + G)		
	Voltage Range	305~478Vac (full load); 228~478Vac (70% load)		
	Current Harmonic Distortion	< 3%**		
	Power Factor	> 0.99		
	Frequency Range	40~70Hz		
<b>Output</b>	Voltage	220/380Vac; 230/400Vac; 240/415Vac (3-phase, 4-wire + G)		
	Voltage Harmonic Distortion	≤ 0.5% (linear load)		
	Voltage Regulation	±1% (static)		
	Frequency	50/60Hz ± 0.05Hz		
	Overload Capability	≤ 125%: 10 minutes; ≤ 150%: 1 minute; >150%: 1 second		
<b>Display</b>		10" color touch screen		
<b>Interface</b>	Standard	RS232 x 1, Parallel port x 4, USB type A x 2, USB type B x 1, MODBUS x 1, Smart slot x 1, REPO x 1, EPO x 1, Input dry contact x 4, Output dry contact x 6, External battery temperature detection x 4, External switch/breaker status dry contact x 4, BMS (RJ45) x 1, Ethernet x 1		
	Optional	Relay I/O card, Battery cabinet temperature sensor cable		
<b>Conformance</b>	Safety	CE		
<b>Efficiency</b>	AC-AC	Up to 96.5%		
	ECO Mode	99%		
<b>Battery</b>	Nominal Voltage	±240Vdc (default, ±180Vdc to ±276Vdc configurable)		
	Charge Voltage	±272Vdc (adjustable from 204Vdc to 312Vdc)		
	Protection of Battery Deep Discharge	Yes		
<b>Environment</b>	Operating Temperature	0~40°C		
	Relative Humidity	0~90% (non-condensing)		
	Audible Noise (at 1 meter)	< 75dB	< 80dB	< 85dB
	IP Protection	IP20		
<b>Others</b>	Parallel Redundancy and Expansion	Module and system redundancy; Maximum 8 units		
	Emergency Power Off	Remote (default) and local (optional)		
	Battery Start	Yes		
<b>Physical</b>	Dimensions (W x D x H)	600 x 1100 x 2000mm		1200 x 1100 x 2000mm
	Weight:			
	UPS System (without power modules)	311 kg	317 kg	605 kg
50kW Power Module (optional)	36 kg			

\* The power module's power rating is adjustable to either 50kVA or 55.6kVA via touch panel.

\*\* When input vTHD is less than 1%.

All specifications are subject to change without prior notice.



# UPS Management

## SNMP IPv6 Card

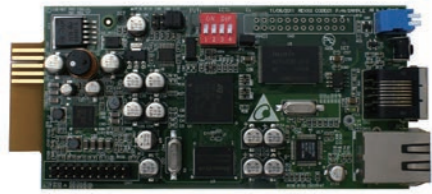

### Functions and Features

#### Network

SNMP	SNMPv1/v3 protocol support; accepts NMS monitoring as well as actively sends Trap packets to target hosts Support IPv4 and IPv6 TCP/IP protocol
HTTP/HTTPS	Monitor and set up through network browser with built-in web server
Others	Telnet, SSH, FTP, SFTP, BOOTP, DHCP, SMTP, SNTP, WOL and RADIUS, Syslog
MIB	Supports RFC1628 and Delta proprietary UPSv4 MIB, UPSv5 MIB, Modbus TCP

#### Management

Regular power on and off	Can set up UPS power on and off time
Regular testing	Battery discharge test ensures the battery is in good condition
Smart Shutdown	Can send power off signal to connected host actively if the host computer has the ShutdownAgent installed
Probe	Optional environment probe can integrate ambient temperature and humidity for total cabinet monitoring

#### Diagnosis

Event log	Keep date, time, and event sequence in event log file
History records	Keep date, time, and UPS parameter data. Can be exported into XLS file for further processing

#### Reaction to events

UPS shutdown	Define delay time for UPS power off to avoid deep discharge
Email	Send email notification to predefined recipients in case of power event

#### Application

Integrate the communication requirement of UPS, PDC, STS, Rack STS and cooling with dip switches selection on one single SNMP IPv6 card

### Technical Specifications

<b>10/100M RJ45 Connector</b>	
Operation Temperature	0~60°C
Input Power	12Vdc
Power Consumption	< 2W
Dimensions	130 x 60mm
Weight	75g

## Relay I/O Card



### Functions and Features

#### Output

Programmable	6 output relays, each of them can be configured to represent one of the 20 UPS events respectively
NC/NO	6 output relays, each of them can be configured to either NC (Normal Close) or NO (Normal Open)

#### Input

Programmable	The input signal can be configured to turn off the UPS or to issue battery test command
--------------	---

### Technical Specifications

Operation Temperature	0~40°C
Input Power	8~20Vdc
Power Consumption	< 1.2W
Dimensions	130 x 60mm
Weight	200g

## Modbus Card

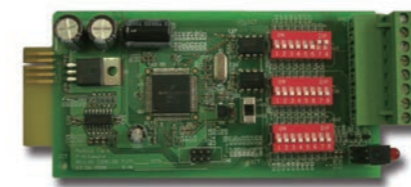

Converts status and parameter data of your UPS to comply with the standard Modbus protocol

### Functions and Features

Communications interface	1 x RS232 port; 1 x RS485 or RS422 port
ID	Device ID can be set to any number between 0~255
Terminating resistor	Terminating resistance of RS485 / 422 can be set by dip switch
Modbus communications format	Supports RTU format
Baud rate	2400, 4800, 9600 or 19200
Data bit	7 or 8
Parity check	None, even or odd

### Technical Specifications

Operation Temperature	0~40°C
Input Power	8~20Vdc
Power Consumption	< 1.2W
Dimensions	130 x 60mm
Weight	150g

# UPS Management

## Mini SNMP IPv6 Card



### Functions and Features

<b>Network</b>	
SNMP	SNMPv1, v2c and v3 protocols support; accepts NMS monitoring as well as actively sends Trap packets to target hosts; supports IPv4 and IPv6 TCP/IP protocol
Web	Monitor and set up through network browser with built-in web server
Protocol	HTTP, HTTPS, Modbus TCP, Telnet, SSH, FTP, SFTP, DHCP, SMTP, SNMP, RADIUS, Syslog, and WOL
MIB	Supports RFC1628 and Delta proprietary UPSv4 MIB, UPSv5MIB

<b>Management</b>	
Regular power on and off	Can set up UPS power on and off time
Regular testing	Battery discharge test ensures the battery is in good condition.
Smart Shutdown	Can send power off signal to connected host actively if the host computer has ShutdownAgent installed
Probe	Optional environment probe can integrate ambient temperature and humidity with 4 additional digital inputs for total cabinet monitoring

<b>Diagnosis</b>	
Event log	Keep date, time, and event sequence in event log file
History records	Keep date, time, and UPS parameter data. Can be exported into XLS file for further processing

<b>Reaction to events</b>	
UPS shutdown	Define delay time for UPS power off to avoid deep discharge
Email	Send email notification to predefined recipients in case of power event

### Technical Specifications

Network Connection	RJ-45 jack connector
Operation Temperature	0~60°C
Input Power	12Vdc
Power Consumption	2 Watt Maximum
Dimensions	87 x 70 x 30mm
Weight	75g

## Mini USB Card



### Functions and Features

Communication Protocol	SCI: Delta Regular v1.51 USB: Delta HID Protocol v3.4
Supports HID (Human Interface Device) protocol	The UPS can communicate with Windows XP/2003/2008/2012/Win7/Win8 without monitoring software
Compatible with Delta UPS standard software	UPSentry 2012

### Technical specifications

Operating Temperature	0~40°C
Input Power	12Vdc
Power Consumption	0.5Watts
Dimensions	68 x 43mm
Weight	30g

## Mini Dry Contact Card



### Functions and Features

- UPS status information presented as 3 contact closures
- Configurable input signal as shutdown UPS or battery test
- Programmable output contact monitors status of UPS
- Configurable UPS shutdown delay time
- Protects up to 3 computers
- Unattended graceful shutdown

### Technical specifications

Operating Temperature	0~40°C
Input Power	8~20Vdc
Power Consumption	0.8Watts
Dimensions	68 x 43mm
Weight	35g

# UPS Management

## Mini TVSS Card



### Functions and Features

- This connection is optional but highly recommended as network lines often carry dangerous surges and spikes
- Connect the Network Protection Lines  
Connect the network line from the wall to the connector marked "IN", then connect the device (Ethernet card) to be protected to the connector marked "OUT"

### Technical Specifications

Operation Temperature	0~40°C
Dimensions	46 x 43mm
Weight	25g

## Delta UPS Management Software

### Communications mechanism

	RS232	USB	RS485	SNMP
UPSentry 2012	•	•		
InfraSuite Device Master	•		•	•
ShutdownAgent 2012				•

### Key functions

	Shutdown OS	Centralized management	Remote control	Virtual Machine Shutdown			
				Hyper-v	ESXi	XenServer	KVM
UPSentry 2012	•		•	•		•	•
InfraSuite Device Master		•	•				
ShutdownAgent 2012	•			•	•	•	•

### Operating system support

	Windows	Linux
UPSentry 2012	•	•
InfraSuite Device Master	•	
ShutdownAgent 2012	•	•

## Shutdown Agent 2012

### Functions and Features

- Supports SNMPv1, v3 trap
- Provides web interface through HTTP and HTTPS
- Provides batch configuration to deploy settings with the snap of a finger
- Forwards SNMP trap to extend protecting more than 255 servers
- Supports up to 32 input trap sources for redundant (logical OR) and parallel (logical AND) application
- Provides console configuration for basic system parameters setup
- Supports Windows and Linux 32/64 bits setup programs

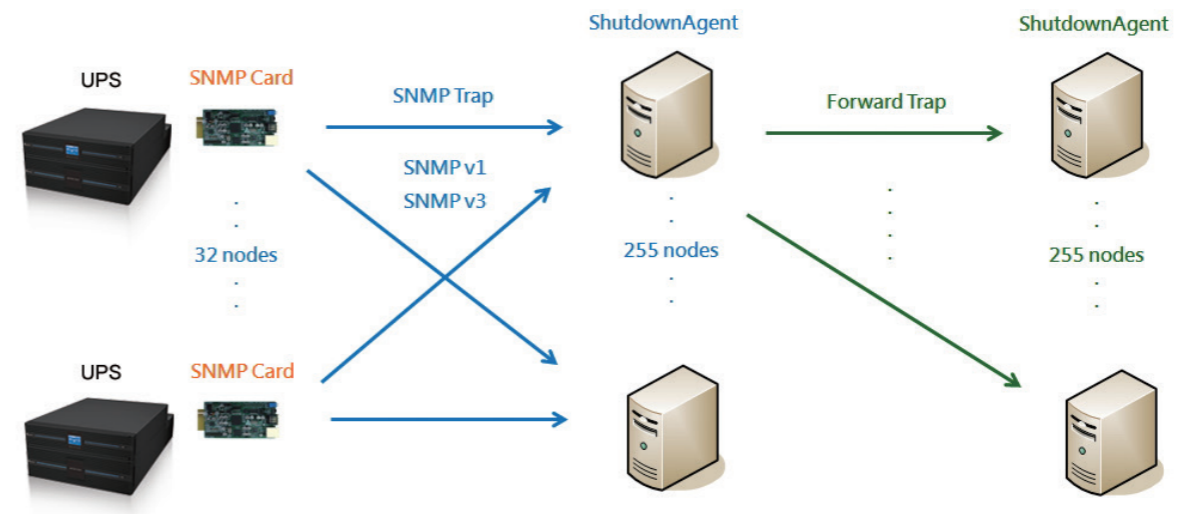

### Operating System Support

- Windows 7, 8, 10
- Windows Server 2008, 2012, 2016, 2019
- Windows 2008/2012 Server Core, Hyper-V 2008/2012
- Redhat Linux Enterprise 8.3
- Oracle Linux 7.1
- Linux OpenSUSE 11.4
- Linux ubuntu 10.04
- Linux Fedora 3.1.9
- VMWare ESXi 4.1, 5, 5.1, 5.5, 6, 7 (with essential license after version 5)
- Citrix XenServer 6.0.0
- Linux KVM
- IBM AIX 7.1

# UPS Management

## UPSentry 2012

### Functions and Features

- Supports RS232 and USB communication
- Provides web interface through HTTP and HTTPS
- Provides batch configuration to deploy settings with a snap of finger
- Supports SNMP Trap v1, v2c, v3
- Supports SNMPv1, v3 server access for monitoring UPSentry 2012 status and configure shutdown parameters
- Works with ShutdownAgent 2012 to protect a huge number of hosts
- Provides console configuration for basic system parameters setup
- Supports Windows and Linux 32/64 bits software programs

### Operating system support

- Windows 7, 8, 10
- Windows Server 2008, 2012, 2016, 2019
- Windows 2008/2012 Server Core, Hyper-V 2008/2012
- Redhat Linux Enterprise 8.3
- Oracle Linux 7.1
- Linux OpenSUSE 11.4
- Linux ubuntu 10.04
- Linux Fedora 3.1.9
- CentOS 5.8
- Citrix XenServer 6.0.0
- Linux KVM

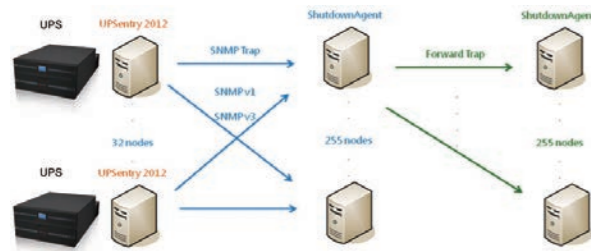

### Event Tracking

- Supports 10,000 event log entries
- Displays history values by a single date, month and year or a defined period of time
- Exports data in csv. file format
- Clears the history data and event logs on the web interface



### Scheduling

- Supports scheduling shutdown, restart and battery test
- System power on/off
- 10 seconds test and deep discharge test

### Shutdown Protection

- Input power fail
- Battery low
- Overload
- Bypass
- Schedule Shutdown

### Web Interface

- Monitors UPS status through web interface
- System Summary: UPS identification, shutdown type, scheduling information and last five event log
- Battery: battery status, battery measurement, battery cabinet and replacement date
- In/Out/Bypass: Information of input measurement, bypass measurement and output measurement
- Identification: Information of identification and UPS rating
- Status Indication: Information of immediate UPS status indication
- Power Module: Information of power module bypass and power module ID1/2/3/4
- Shutdown Agent: Collect all of the ShutdownAgent 2012 which you have assigned to work with UPSentry 2012 to protect a group of servers
- Displays event log and history values

## EnviroProbe



### Functions and Features

- LCD display
- Ambient temperature & humidity monitoring and water-leakage detection
- Digital & analog input/output contacts for monitoring and controlling other devices
- Supports SNMP communications protocol
- InfraSuite Device Master software for remote monitoring and recording

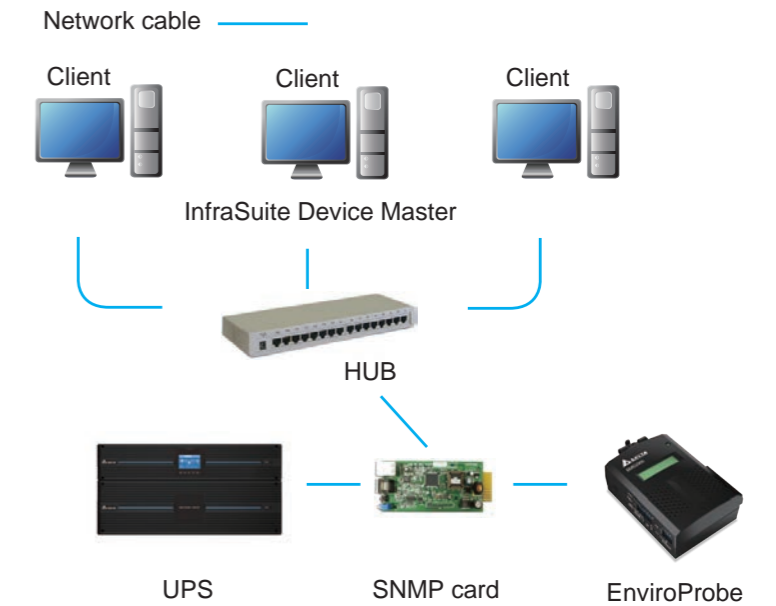

### Technical Specifications

Model	EMS1000	EMS1100	EMS1200
Input	EMS2000 Delta-BUS or SNMP Card: 12Vdc (pin 1 & 4) with PDU SNMP card: 5Vdc (pin 2 & 4)		
Input/Output Contacts	4 inputs (dry/wet)	4 digital outputs	2 analog inputs, 1 analog output and 1 water-leakage detection.
Dimensions (W x D x H)	66 x 33 x 103mm		
Weight	120g	130g	130g
Temperature	±0.4°C @ 0~60°C		
Humidity Accuracy	±3% RH @ 0~80% RH		
Safety Regulation Compliance	CE, EN55022 Class B, EN55024		

# UPS Management

## Delta InfraSuite Device Master

InfraSuite Device Master provides a rich set of capabilities that simplify and automate critical device monitoring. It allows users to observe the status of all devices, query event logs or history data, and assists users in taking appropriate action. With cost effective deployment, this software solution is scalable to match your business growth.

### Free to Download

InfraSuite Device Master is free to download with 5 nodes by default for monitoring your devices. Various infrastructure facilities such as power and cooling in a data center can be monitored.

### Easy to Deploy

The download file is ready on the Delta Software website. InfraSuite Device Master is easy to install on your server or PC, with software designed for quick installation and implementation.

### Real-Time Monitoring

Users can gather the latest status of critical facilities in a data center through the system screens of InfraSuite Device Master. InfraSuite Device Master also lets you view all of a site's device information, query history and events at the same time, even for multiple sites in different countries.

### Migration to InfraSuite Manager (DCIM)

If you are not only looking for device monitoring but also a complete DCIM solution, InfraSuite Device Master is the quickest way of migrating to InfraSuite Manager, which is Delta's full feature DCIM software solution.

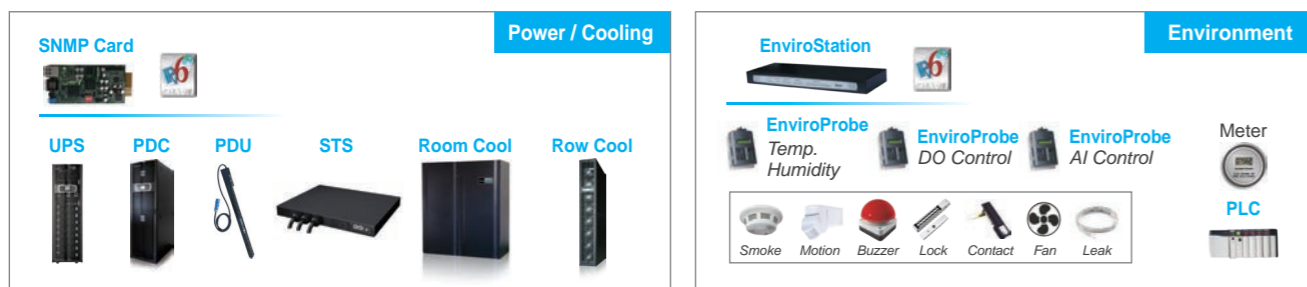
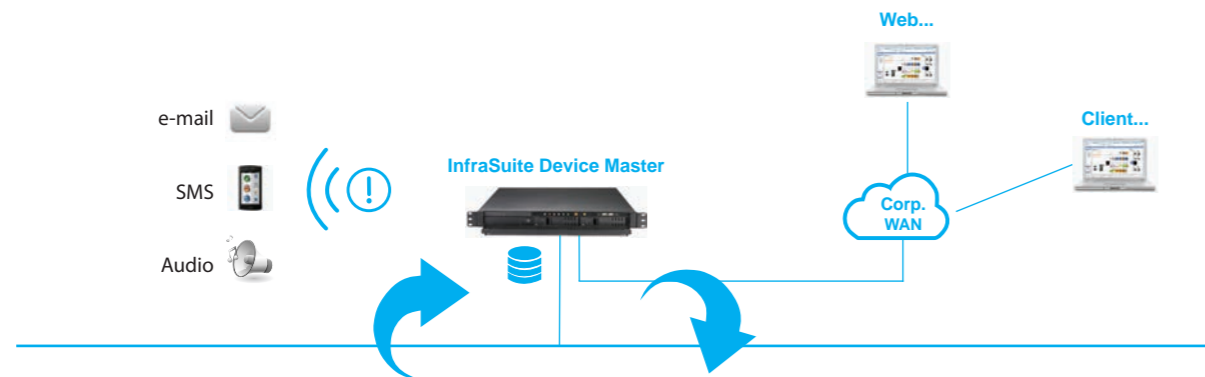

FIGURE 1. Delta InfraSuite Device Master Monitoring Application

**Free Download** To download InfraSuite Device Master, go to;  
<http://www.deltapowersolutions.com/en/mcis/data-center-infrasuite-device-master.php>

## Product Features

### Navigational Graphics

Navigational graphics of the InfraSuite Device Master are customizable. Users can design a floor layout using the provided components.



FIGURE 2. Navigational Graphics

### Multiple Protocol Support

InfraSuite Device Master supports multiple device protocols, such as Modbus, SNMP and OPC.

### Proactive Notification

Proactive notifications provide automated, personalized email, short messages, and audio to users.

### User Account Management

Users can be classified into groups based on privilege levels. The job scope of each privilege level is defined by administrators. The jobs include the level of visible access to layout plans, device control and system operation.

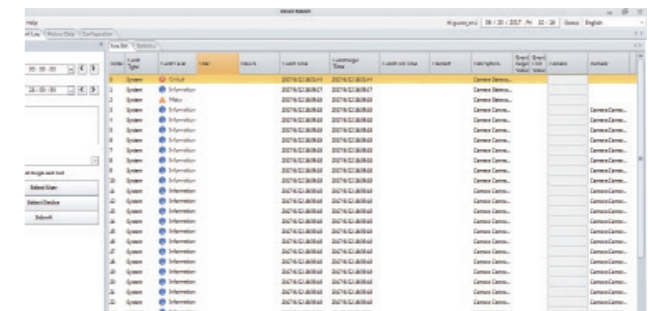

FIGURE 3. Event Log List

### Event Management

InfraSuite Device Master has categorized event levels with 16 levels to help users take appropriate action accordingly. Besides, events can be queried by time, type, level and devices. InfraSuite Device Master records the system, operator and device events in its database where the user can review the events' status.

### Data Storage and Backup

InfraSuite Device Master stores all history events and data into its database. Users may use this data for analysis. In addition, the database can be backed up automatically according to user preference.

## System Requirements

Model	InfraSuite Device Master (Server)	InfraSuite Device Master (Windows Application UI)	InfraSuite Device Master (Web Monitor UI)
<b>Hardware</b>	CPU: > 2GHz Memory: ≥ 4G Free HD Space: ≥ 50 G	CPU: > 2GHz Memory: ≥ 4G	CPU: > 2GHz Memory: ≥ 4G
<b>Software</b>	Supported OS: Windows 7, 8, 10, Windows Server 2008, 2012, 2016, 2019	Supported OS: Windows 7, 8, 10, Windows Server 2008, 2012, 2016, 2019	Recommended Browser: Google Chrome, Mozilla Firefox and Microsoft Edge.

## Europe

### Czech Republic

Delta Energy Systems  
T +420 272 019 330  
E [ups.czech.republic@deltaww.com](mailto:ups.czech.republic@deltaww.com)

### Finland

Delta Solutions (Finland) Oy  
T +358 9 84966 0  
E [ups.finland@deltaww.com](mailto:ups.finland@deltaww.com)

### France

Delta Electronics (France) S.A.  
T +33 1 69 77 82 60  
E [ups.france@deltaww.com](mailto:ups.france@deltaww.com)

### Germany

Delta Energy Systems (Germany) GmbH  
T +49 2921 987 0  
E [ups.germany@deltaww.com](mailto:ups.germany@deltaww.com)

### The Netherlands - EMEA Headquarters

Delta Electronics (Netherlands) BV  
T +31 (0) 20 800 39 00  
E [ups.netherlands@deltaww.com](mailto:ups.netherlands@deltaww.com)

### Poland

Delta Electronics (Poland) Sp. z.o.o.  
T +48 22 335 26 00  
E [ups.poland@deltaww.com](mailto:ups.poland@deltaww.com)

### Russia

Delta Energy Systems LLC  
T +7 495 644 3240  
E [ups.russia@deltaww.com](mailto:ups.russia@deltaww.com)

### Slovak Republic

Delta Electronics (Slovakia) s.r.o.  
T +421 2 6541 1258  
E [ups.slovakia@deltaww.com](mailto:ups.slovakia@deltaww.com)

### Switzerland

Delta Electronics (Switzerland) AG  
T +41 31 998 53 11  
E [ups.switzerland@deltaww.com](mailto:ups.switzerland@deltaww.com)

### Spain

Delta Electronics Solutions (Spain) SLU.  
T +34 91223 7420  
E [ups.spain@deltaww.com](mailto:ups.spain@deltaww.com)

### Turkey

Delta Greentech Electronic San. Ltd.  
T +90 216 499 9910  
E [ups.turkey@deltaww.com](mailto:ups.turkey@deltaww.com)

### United Kingdom

Delta Electronics Europe Ltd.  
T +44 1355 588 888  
E [ups.united.kingdom@deltaww.com](mailto:ups.united.kingdom@deltaww.com)

## Middle-East & Africa

### South Africa

Delta Energy Systems MEA (Switzerland) AG  
T +27 12 663 2714  
E [ups.south.africa@deltaww.com](mailto:ups.south.africa@deltaww.com)

### United Arab Emirates

Delta Energy Systems (Switzerland) AG  
T +971 425 99 55 3  
E [info.middle-east@deltaww.com](mailto:info.middle-east@deltaww.com)

## Americas

### Brazil

Delta Electronics Brasil Ltda.  
T +55 12 3932 2300  
E [ups.brazil@deltaww.com](mailto:ups.brazil@deltaww.com)

### The United States

Delta Electronics (Americas) Ltd.  
T +1 510 344 2157  
E [ups.na@deltaww.com](mailto:ups.na@deltaww.com)

## Asia Pacific

### Australia

Delta Energy Systems Australia Pty Ltd.  
T +61 3 9543 3720  
E [ups.australia@deltaww.com](mailto:ups.australia@deltaww.com)

### China

Delta GreenTech (China) Co., Ltd.  
T +86 21 5863 5678 / +86 21 5863 9595  
E [ups.china@deltaww.com](mailto:ups.china@deltaww.com)

### India

Delta Power Solutions (India) Pvt. Ltd.  
T +91 124 4874 900  
E [ups.india@deltaww.com](mailto:ups.india@deltaww.com)

### Indonesia

E [ups.indonesia@deltaww.com](mailto:ups.indonesia@deltaww.com)

### South Korea

Delta Electronics (Korea), Inc.  
T +82 2 515 5303  
E [ups.south.korea@deltaww.com](mailto:ups.south.korea@deltaww.com)

### Malaysia

E [ups.malaysia@deltaww.com](mailto:ups.malaysia@deltaww.com)

### Philippines

E [ups.philippines@deltaww.com](mailto:ups.philippines@deltaww.com)

### Singapore

Delta Energy Systems (Singapore) Pte Ltd.  
T +65 6747 5155  
E [ups.singapore@deltaww.com](mailto:ups.singapore@deltaww.com)

### Taiwan

Delta Electronics Inc.  
T +886 6 505 6565  
E [ups.taiwan@deltaww.com](mailto:ups.taiwan@deltaww.com)

### Thailand

Delta Electronics (Thailand) Public Co., Ltd.  
T +662 709 2800  
E [ups.thailand@deltaww.com](mailto:ups.thailand@deltaww.com)

### Vietnam

E [ups.vietnam@deltaww.com](mailto:ups.vietnam@deltaww.com)



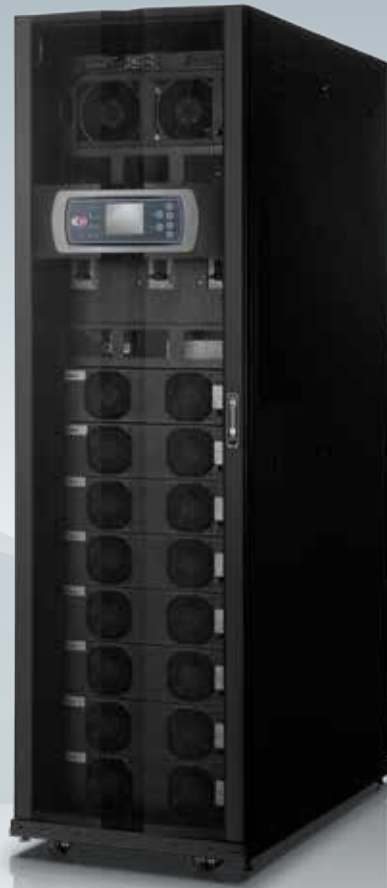

The power behind competitiveness

## Delta UPS - Modulon Family DPH Series, 25 - 800 kW

The modular UPS ideal for medium-sized datacenters

[www.deltapowersolutions.com](http://www.deltapowersolutions.com)



# Table of Content

Introduction	02
Product Overview	04
Management System	09
Technical Specification	10





**Introducing the next generation of modular uninterruptible power supply systems (UPS systems) designed for ultimate availability, excellent performance and high efficiency ideally suited for medium-sized datacenters.**

IT operations are a crucial aspect of most business operations. One of the main concerns of datacenters is operational continuity. The most stringent datacenters require the highest availability possible to sustain mission critical functions, the backbone of business continuity. As data keeps growing and rising energy costs are the norm, datacenters will continue to be power hungry facilities. From a capital investment perspective, maintaining high efficiency and having the flexibility to rightsize a datacenter is a critical concern. The Modulon DPH is a modular UPS ideal for medium-sized datacenters demanding in peak efficiency and availability at a lower Total Cost of Ownership (TCO).

- 1) Fully fault-tolerant design to meet strict requirement on availability due to increased IT-dependent business operation
- 2) Scalable flexibility to rightsize the infrastructure at the right time without overinvestment
- 3) Industry leading power performance and efficiency to save energy cost that reduce the operational expense

The Modulon DPH is in a dimension of 19" enclosure providing rack-based agility to datacenter space arrangement and infrastructure setup. As a powertrain of datacenters, the Modulon DPH can integrate the power distribution in a same rack or through the deployment of paralleled rack enclosure depending on the power capacity requirement, a perfect combination of power protection and distribution to streamline the power management in the datacenters.



The Modulon DPH is designed in modern IT aesthetics aligned with Delta InfraSuite datacenter solutions.



# Product Overview

## Ultimate Availability

- Advanced fault-tolerant design achieved by self redundancy to guarantee operation continuity
- Self-synchronization of power and control modules for continuous on-line operation even in the event of control module failure to avoid downtime caused by single point failure
- Hot-swappable key modules and components to ensure Mean Time To Repair (MTTR) close to zero without downtime risk
- Wide input voltage range of -45% to +25% and narrow output voltage regulation window to cope with harsh utility conditions and seamlessly provide stable power supply to the load
- High overload protection to support 125% overload for 10 minutes and 150% for 1 minute

## High Scalability

- Vertical expansion from 25kW to 200kW supporting N+X redundancy in a single rack enclosure to save footprint
- Parallel expansion up to four units without requiring additional hardware
- Variable configurations possible providing the scalable flexibility up to Tier 4 standard

## Excellent Power Performance and Efficiency

- Fully rated power (kVA=kW) to maximize power availability
- High AC-AC operating efficiency of 95% at 30% light load and 96% from 50% load resulting in marked energy cost savings
- Low harmonic pollution (iTHD<3%) to reduce upstream investment costs and meet demanding power requirements

## Easy Maintenance

- Built-in manual bypass to eliminate maintenance-related downtime
- Proactive detection of fan failure and switch fault for early diagnosis on UPS malfunction
- Plug and play to simplify the maintenance process

## Applications



Datacenter



Telecom



Industrial



Network



Security



Lab



Medical



Metro



Banking



The Modulon DPH supports ultimate availability to ensure the continuity of mission critical operations.

## Ultimate Availability for Mission Critical Operations

The datacenter constitutes the critical load in the daily operations of the organization. Cost of downtime due to critical load failure is extreme and runs between USD4,000 to USD6,000 per minute or even more. To achieve the highest availability possible for the datacenter, it is vital for the most reliable products or solutions supported by the shortest or even zero Mean Time To Repair (MTTR).

The fully fault-tolerant design provides self redundancy to the control mechanism, cooling and power modules. Full control logic allows the system to self-synchronize in the event of main module failure and automatically switch to the backup for assured continuous operation.

Furthering the advantages, the hot-swappable functionality of critical components and modules improve the serviceability of the UPS system thereby reducing MTTR close to zero to assure maximum uptime and ultimate availability in the datacenters.

As illustrated, the Modulon DPH can run under inverter mode and bypass mode to sustain uninterruptible power supply to critical load:

In the event of STS module removal, the Modulon DPH still functions under inverter mode (normal mode without bypass utility backup). During failure in normal mode, such as over temperature, overload, short circuit, abnormal output voltage, or low battery, the Modulon DPH smoothly transfers over to bypass mode.

In addition, the Modulon DPH has a wide input voltage range of -45% to +25% and narrow output voltage regulation window to cope with harsh utility conditions, seamlessly providing stable power supply to the load. In the event of overload, the Modulon DPH supports 125% overload protection for up to ten minutes and one minute at 150%.

The Modulon DPH assures exceptional reliability and maximizes uptime to deliver six-nines availability contributing to the best-in-class practice to reduce Total Cost of Ownership (TCO).

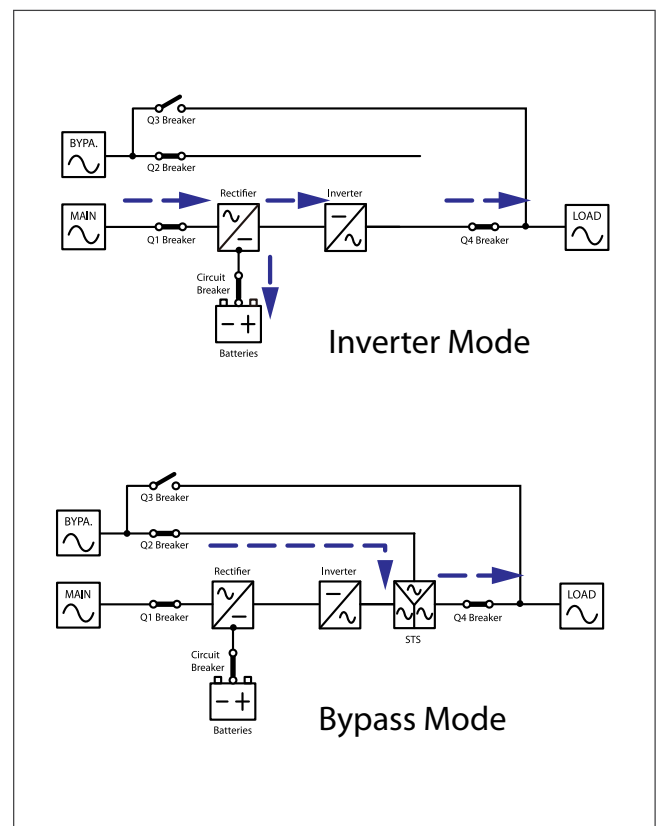



## Modularity Designed for Scalability

Scalable architecture allows you to optimize cost expenditure to meet your power demands and deliver uninterrupted services in line with the business growth without over-sizing the power capacity.

The plug and play design of power module supports vertical and horizontal expansion of power capacity at the right time with the right investment. In the situation of a single rack enclosure, the system can vertically scale from 25kW to 200kW and achieve N+1 or N+X

redundancy in the same rack. As business demands grow, the flexibility of the Modulon DPH allows for parallel expansion of up to four units without requiring additional hardware.

The Modulon DPH offers the advantages you need without the high initial investment costs or sacrificing power capacity so as not to create investment excess due to capital waste.

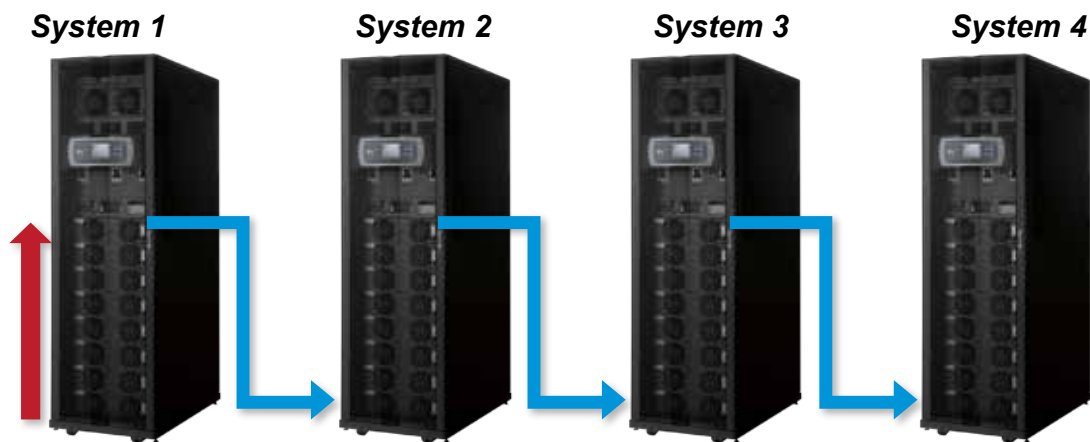

### VERTICAL MODULARITY

from 25 to 200 kW

- On-site upgradable to 8 power modules within a rack
- Hot-scalable

### HORIZONTAL MODULARITY

up to 800kW

- Parallel expansion up to 4 units
- Easy connection by parallel wire



Excellent power performance and efficiency directly translate into significant reduction of operational costs.

## Excellent Power Efficiency and Performance

Two key trends have developed in the world of datacenter operations – demand for power and the cost of that power. Today’s management is facing growing pressure to optimize performance for sustainability and growth.

Delta’s UPS solutions deliver one of the highest power performance and efficiency ratings available while reducing cost. The Modulon DPH delivers fully rated power (power factor=1, kVA=kW) providing the maximum power capacity to the load. Compared to UPS systems with output of PF=0.8 and PF=0.9, the DPH supplies 25% and 11% more power, respectively. Other than that, the fully rated power factor is supported by a “stronger” inverter design providing better power protection and quality to loads.

The Modulon DPH demonstrates excellent power performance with low total input harmonic distortion (iTHD<3%). Its reduced load pollution increases power quality, optimizes generator sizing to increase your investment savings, reduces installation costs, and extends the life of valuable equipment.

The Modulon DPH features excellent AC-AC efficiency up to 96% at half load and places itself among the highest in its class. In addition to energy saving, higher efficiency levels also mean less heat dissipation, giving way to lower cooling costs.

Excellent power performance and efficiency lower operation costs significantly. The Modulon DPH combines these benefits to provide high performance, efficient power protection to maximize operational savings for any datacenter.

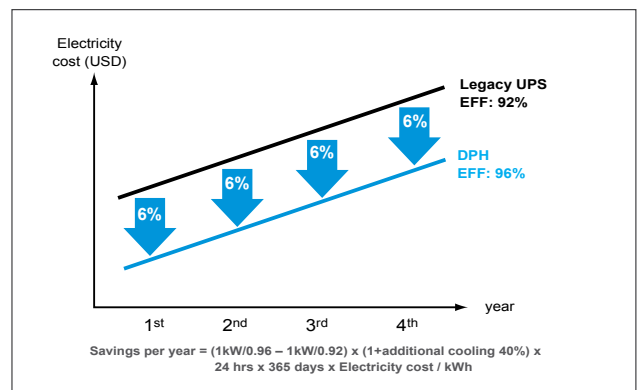
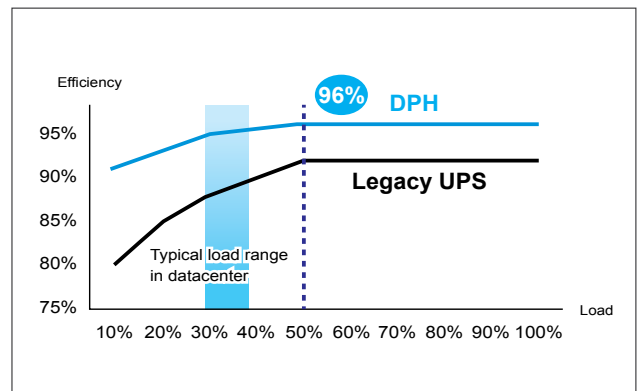
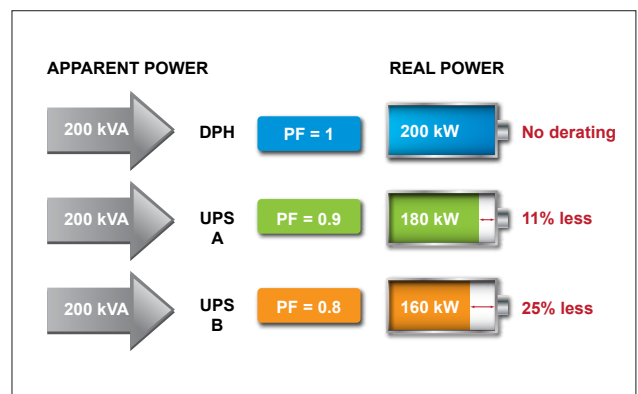

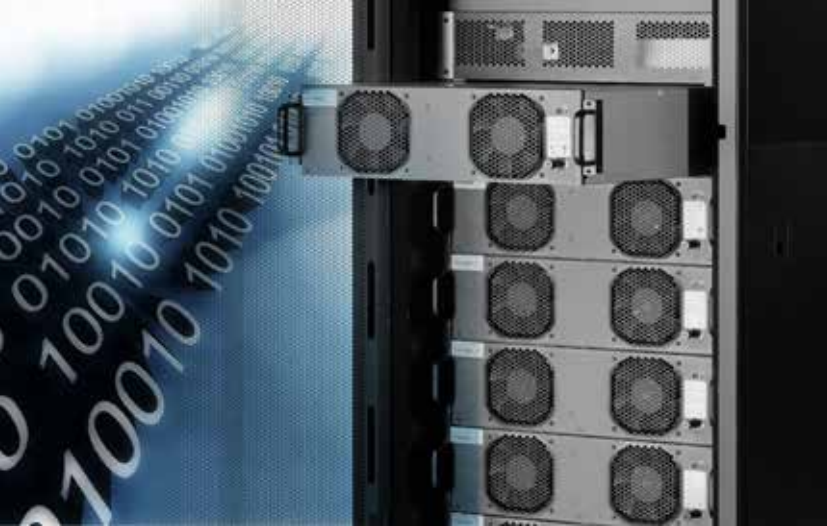

Hot plug and hot swap simplify the maintenance process.

## Easy Maintenance

The Modulon DPH hot plug and hot swap architecture makes best use of a modularity design for 50% faster time of repair compared to traditional UPS systems. Plug and play modularity also eliminates the risk of second fault occurrence caused by complex failure checking and removing processes. The reliability of maintenance and service is guaranteed, further assuring the system availability.

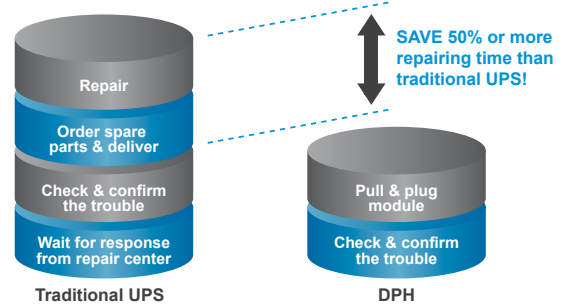

## Architecture

Hot-swappable Control Module

Hot-swappable STS Module

Multi-language LCD Control Panel

Output Breaker

Bypass Breaker

Main Input Breaker

Hot-scalable Power Module (up to 8 units)

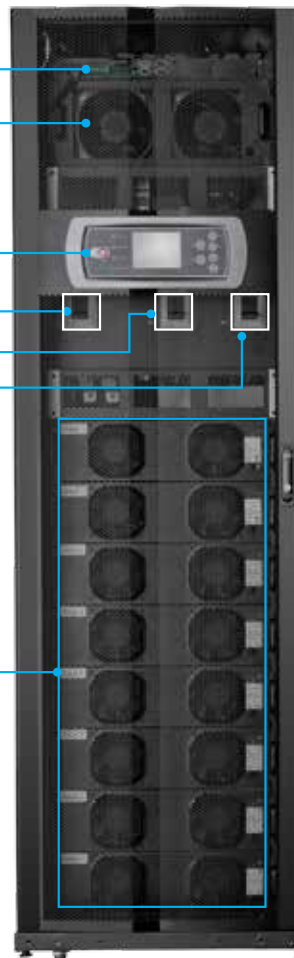



Remote control and monitor datacenter at the tip of your fingers

## Management System

### User-friendly Control Interface

Designed for management ease, the Modulon DPH is fully equipped with user-friendly monitoring and controls in various languages. A big graphic LCD screen provides the needed control for all communication and command options at the tip of your fingers to monitor and control functions on a single page view. Direct event log viewing helps quickly diagnose events without additional hardware requirements. Up to 3,000 event logs can be recorded.



### Integrated Monitoring and Management

Delta UPSentry 2012 communicates with UPS through physical interface RS232 and USB for UPS manageability. Also works with Shutdown Agent 2012 to protect a group of PCs, workstations, or servers. Delta New Shutdown Agent cooperates with SNMP card or UPSentry 2012 to shut down multi-servers in various operating system and virtual machine gracefully to prevent possible data corruption. Furthermore, Modulon DPH can be monitored and controlled together with other datacenter equipment by Delta InfraSuite Manager (EMS 3000) as a total datacenter control and monitoring solution.

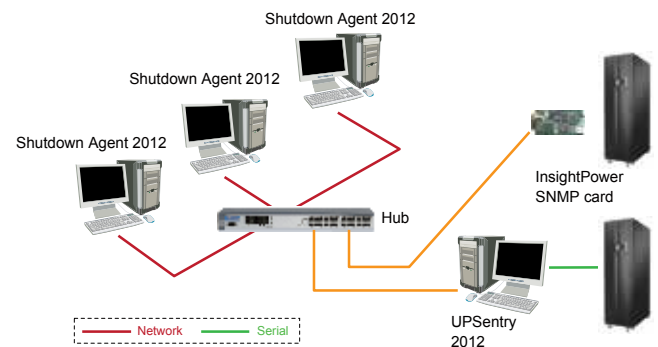

### Intelligent Battery Management System

Delta intelligent battery management system can sustain battery lifespan and the capacity of battery backed up through the functions of:

- Battery temperature monitoring & compensation
- Battery remaining capacity displayed in percentage
- Overcharge/discharge protection
- Boost/float stage charge
- Auto/manual battery test
- Adjustable charging voltage from 254V to 291V adapts to different types of batteries
- Up to 40A charging current even at full load conditions
- 38~42 battery units in one battery cabinet optimizes investment

# Technical Specification

Model		DPH							
Power Rating (kVA)		25	50	75	100	125	150	175	200
Power Rating (kW)		25	50	75	100	125	150	175	200
Input	Nominal Voltage	380/220V, 400/230V, 415/240V (3 phase, 4-wire +G)							
	Voltage Range	176~276 / 305~477 Vac *							
	Current Harmonic Distortion	< 3% **							
	Power Factor	> 0.99							
	Frequency	50/60 Hz							
Output	Voltage	380/220V, 400/230V, 415/240V (3 phase, 4-wire +G)							
	Output Power Factor	1 (kVA=kW)							
	Voltage Harmonic Distortion	≤ 2% (linear load)							
	Voltage Regulation	± 1% (static)							
	Frequency	50 or 60 Hz							
	Frequency Regulation	± 0.05 Hz							
	Overload Capacity	≤ 125%: 10 minutes; ≤ 150%: 1 minute							
Interface	Standard	Parallel port x 2, Smart slot x 2, Dry contact output x 6, Dry contact input x 6, Battery dry contact x 6							
	Optional	SNMP card IPv6, ModBus card, Relay I/O control card, EnviroProbe, Battery cabinet temperature sensor, Battery cabinet status cable							
Conformance	Safety & EMC	CE, EN62040-1							
Other Features	Parallel Redundancy and Expansion	Module and system redundancy; Maximum 4 units up to 800 kW							
	Emergency Power Off	Local and remote							
	Battery start	Yes							
	Event Log	3000 records							
	External Battery Cabinet	Optional							
Efficiency	AC-AC	96%							
	ECO Mode	99%							
Environment	Operating Temperature	0 ~ 40 °C							
	Relative Humidity	0 ~ 90% (non-condensing)							
	Audible Noise (at one meter)	< 62 dBA							
Physical	Dimensions (WxDxH)	600 x 1090 x 2000 mm							
	Weight	382 kg	414 kg	446 kg	478 kg	510 kg	542 kg	574 kg	606 kg

\* When input voltage is 140/242~176/305 Vac, the sustainable loading is from 60% to 100% of the UPS capacity.

\*\* When input harmonic distortion is less than 1%.

All specifications are subject to change without prior notice.



2007~ 2008 Forbes Asia's Fabulous 50



2009 Frost & Sullivan Green Excellence Award for Corporate Leadership



Delta's Manufacturing System Certified by ISO 9001 and ISO 14001 Standards



IECQ Certificate of Hazardous Substance Process Management



## Europe

### Czech Republic

Delta Energy Systems (Czech Republic), spol.s r.o.  
Perucka 2482/7  
120 00 Praha 2  
Czech Republic  
T +420 272 019 330  
F +420 271 751 799

### Finland

Delta Energy Systems (Finland) Oy  
Juvan teollisuuskatu 15  
02921 Espoo  
T +358 9 84966 0  
F +358 9 84966 100

### France

Delta Energy Systems (France) S.A.  
ZI du bois Chaland 2 15 rue des Pyrenees,  
Lisses  
91056 Evry Cedex  
T +33 1 69 77 82 60  
F +33 1 64 97 05 77

### Germany

Delta Energy Systems (Switzerland) AG  
German Office  
Coesterweg 45, D-59494 Soest  
59494 Soest  
T +49 2921 987 337  
F +49 2921 987 396

### Italy

Delta Energy Systems (Italy) S.R.L.  
Piazza Grazioli 18  
00186 Roma  
T +39 06 699 41 209  
F +39 06 699 42 293

### Poland

Delta Energy Systems (Poland)  
Sp. z.o.o. 23 Poleczki Str.  
02-822 Warsaw  
T +48 22 335 26 00  
F +48 22 335 26 01

### Russia

Delta Energy Systems (Russia)  
Vereyskaya Plaza II, office 503,  
Vereyskaya str.17  
121357 Moscow, Russia  
T +7 495 644 32 40  
F +7 495 644 32 41

### Slovak Republic

DELTA ELECTRONICS (SLOVAKIA), s.r.o.  
Botanická 25/A, SR-841 04 Bratislava,  
T +421 (0)2 6541 1258  
F +421 (0)2 6541 1283

### Spain

Delta Energy Systems (Spain)  
S.L. Calle Luis I  
nº 60, Nave 1a, P.I. de Vallecas  
28031 Madrid  
T +34 91 223 74 20  
F +34 91 332 90 38

### Sweden

Delta Energy Systems (Sweden) AB  
P.O.Box 3096  
35033 Växjö  
T +46 470 70 68 16  
F +46 470 70 68 90

### Switzerland

Delta Energy Systems (Switzerland) AG  
Freiburgstrasse 251  
3010 Bern-Bümpliz  
T +41 31 998 53 11  
F +41 31 998 54 85

### Turkey

Delta Greentech Electronic San. Ltd.  
Sti. Serifali Mevkii Barbaros Bulvari Söylesi Sok.  
No: 19, K1, Y.Dudullu-Umraniye  
34775 Istanbul  
T +90 216 499 9910  
F +90 216 499 8070

### United Kingdom

Delta Electronics Europe Ltd.  
1 Redwood Court  
Peel Park, East Kilbride  
G74 5PF  
T +44 1355 588 888  
F +44 1355 588 889

## Middle-East & Africa

### South Africa

Delta Energy Systems MEA (Switzerland) AG  
South Africa Representative Office  
Unit 305B, Lougardia Building,  
Cnr Embankment and Hendrik Verwoerd Drive,  
Centurion  
T +27 12 663 2714  
F +27 86 667 0469

## Americas

### Argentina

Delta Greentech  
Sarmiento 1889 5A  
Buenos Aires  
T +5411 4372 310

### Brazil

Delta Energy Systems (Brazil) S/A  
Rua Itapeva, Nº 26 - 3º andar  
01332 000 - São Paulo - SP  
T +55 11 3568 3874  
F +55 11 3568 3865

### Colombia

Delta Greentech  
Calle 213 # 114-10 manzana 14 casa 25  
Caminos de Arrayanes  
T +57 1 673 4927  
F +57 1 673 4927

## Asia Pacific

### China

Delta GreenTech (China) Co., Ltd.  
No.238 Minxia Road, Pudong  
P.R.C 201209 Shanghai  
T +86 21 5863 5678  
+86 21 5863 9595  
F +86 21 5863 0003

### India

Delta Power Solutions (India) Pvt. Ltd.  
Plot No. 43, Sector-35, HSIIDC,  
Gurgaon-122001, Haryana, India  
T +91 124 4874 900  
F +91 124 4874 945

### Taiwan

Delta Electronics Inc.  
39 Section 2, Huandong Road, Shanhua  
Township  
Tainan County 74144, Taiwan  
T +886 6 505 6565  
F +886 6 505 1919



Best Space  
Utilization



Leading Energy  
Efficiency



Battery Health  
Prediction



Ready for  
Li-ion Batteries

# Delta UPS - Ultron Family DPS Series 300-1200kVA

The Ultimate MW Power Protection with Uncompromising  
Power Performance and Reliability

[www.deltaww.com](http://www.deltaww.com)  
[www.deltapowersolutions.com](http://www.deltapowersolutions.com)

 **DELTA**  
Smarter. Greener. Together.

# About Delta Group

## Leading expert in power management and thermal management solutions

Delta, founded in 1971, is a global leader in switching power supplies and thermal management products with a thriving portfolio of smart energy-saving systems and solutions in the fields of industrial automation, building automation, telecom power, data center infrastructure, EV charging, renewable energy, energy storage and display, to nurture the development of smart manufacturing and sustainable cities. As a world-class corporate citizen guided by its mission statement, "To provide innovative, clean and energy-efficient solutions for a better tomorrow," Delta leverages its core competence in high-efficiency power electronics and its CSR-embedded business model to address key environmental issues, such as climate change. Delta serves customers through its sales offices, R&D centers and manufacturing facilities spread over close to 200 locations across 5 continents.

**World No. 1** in Switching Power Supplies, DC Brushless Fans and Telecom Power Systems

**176** sales offices and **38** manufacturing facilities worldwide

**8%** of annual sales revenues invested in R&D with over **9,000** engineers in **75** R&D centers worldwide

Awarded **10,119+** patents and received **47** internationally recognized design awards including iF, Reddot, and the Taiwan Excellence awards.

## Worldwide No. 1 supplier of merchant power supplies

### The Total Merchant Power Supply Market 2019 Revenue

Ranking	Company Name	Sales (M/USD)
1	Delta Electronics	\$ 5308
2	Schneider Electronic	\$ 3500
3	Vertiv	\$ 2500

Source: Micro-Tech Consultants, 2019

## CSR Honors and Awards

Member of  
**Dow Jones Sustainability Indices**  
Powered by the S&P Global CSA

---

2011 – 2020  
DJSI - World Index  
2018-2020 Industry Leader

**CDP**  
DISCLOSED RESPONSIBILITY ACTION  
**A LIST 2020**  
**CLIMATE**

---

2020  
Climate Change  
Leadership Level

**CDP**  
DISCLOSED RESPONSIBILITY ACTION  
**A LIST 2020**  
**WATER**

---

2020  
Water Security  
Leadership Level

**Sustainability Award**  
Gold Class 2021  
**S&P Global**

---

2021  
Sustainability Award  
Gold Class

# Global Footprint

	Asia-Pacific	Americas	EMEA	Total
Sales Offices	107	24	45	176
Plant Sites	31	4	3	38
R&D Centers	52	9	14	75



More information about Delta Group can be found at [www.deltaww.com](http://www.deltaww.com) or [www.deltapowersolutions.com](http://www.deltapowersolutions.com)



# Data Center Footprints

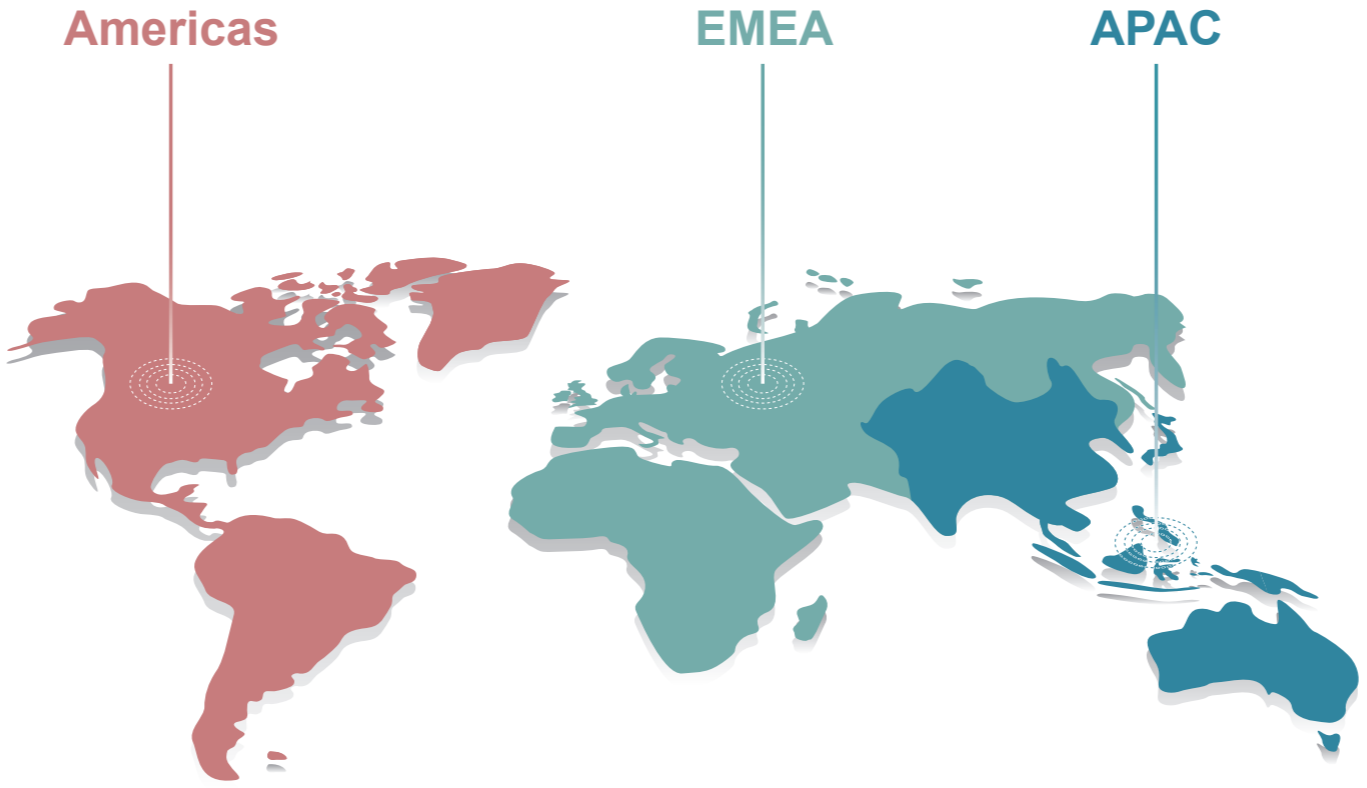

Total Deployment  
Over **1000** MW +



**U.S**  
Power Protection for the "Grab & Go" Shopping Store 1.8 MW



**Russia**  
Government Data Center 1.6 MW



**China**  
Lin Kong Port Data Center 26 MW  
Internet Data Center 5 MW



**Vietnam**  
HTC-ITC, TCCF TIER III-Certified Data Center 750 kW



**Brazil**  
Power Protection for the Largest Private Sector Bank 1.6 MW



**Spain**  
Atos Data Center 200 kW



**Taiwan**  
National Data Center 5.5 MW  
Formosa Plastics Data Center 750kW



**India**  
NetMagic Data Center 22 MW  
Yotta Corp, Colocation 1 MW



**South Africa**  
University Data Center 150 kW



**Netherland**  
Bytesnet, Colocation 6 MW



**Thailand**  
Telecom Data Center 5.2 MW



**Australia**  
Prefabricated Modular Data Center 100MW+

# Ultron DPS Series 300 - 1200kVA

The world's highest power density UPS providing ultimate MW power protection with leading power performance and superior reliability

The dawn of the cloud era went hand-in-hand with the advent of the hyperscale data center. A lot of data moved from on-premise enterprise facilities to the cloud. Delta's superior Ultron DPS series 300 - 1200kVA UPS supports unity output power factor to deliver up to 9.6 MW power capacity to meet the demands of large data centers and colocations that require higher power capacity. The Ultron DPS series guarantees the highest level of system reliability and resiliency by supporting self-detection of key components with a pre-warning function, multi-layered redundancy design, and complete power rating coverage. Moreover, the DPS series supports advanced manageability. Key environment parameters, and event analysis can all be monitored via local 10" LCD monitor and remotely. Along with optional battery management software, the DPS series enables users to achieve predictive maintenance and minimize system downtime, while optimizing the total cost of ownership (TCO).

- 1 Touch panel
- 2 EPO bottom
- 3 Power modules cabinet
- 4 Control system unit
- 5 System STS module
- 6 Input switch
- 7 Bypass switch
- 8 Manual bypass switch
- 9 Output switch
- 10 I/O cabinet



300kVA



1200kVA



300kVA



1200kVA

## Applications for the Ultron DPS Series

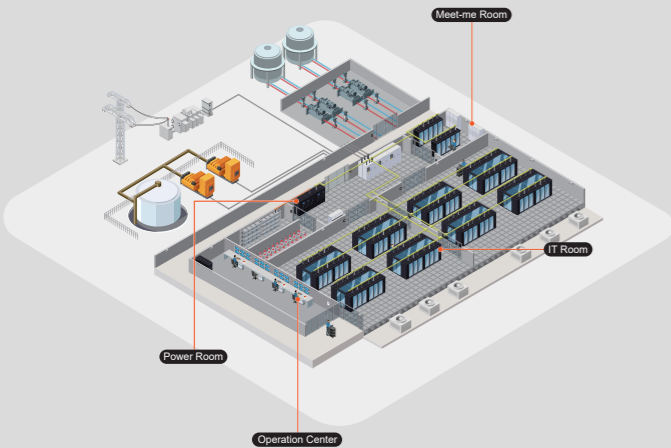

The MW UPS Answering the Demands of Large Data Centers and Colocations

**Highest Power Density at the MW Scale**

Reserves more space for critical equipment

**Sophisticated Manageability**

Integrates related data for easy access via LCD monitor

The Power backup solution for your critical equipment / production line

**Industry-leading Reliability**

Adopts advanced features to enhance reliability and maximize uptime

**Sophisticated Manageability**

Integrates related data for easy access via LCD monitor

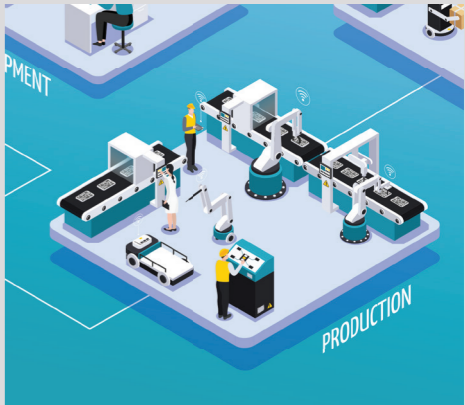

# Ultra Compact Design Excellent Power Performance and Efficiency

## Ultra Compact Design

The industry's leading power density and smallest footprint UPS is designed with both top/ bottom cable entry and inbuilt switches, which allows you to flexibly utilize the space under high power requirements. This high power density means less space is consumed by power infrastructure.

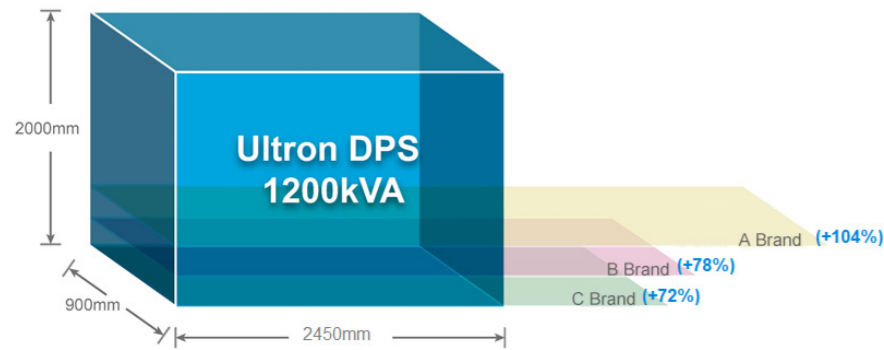

## Leading AC-AC Efficiency in Online Mode

Delta is firmly committed to making data centers as green as possible. The DPS series UPS is the best choice with its AC-AC conversion efficiency of up to 96.5% in normal operation and 99% in ECO mode. This high energy efficiency results in considerable energy savings for large data centers.

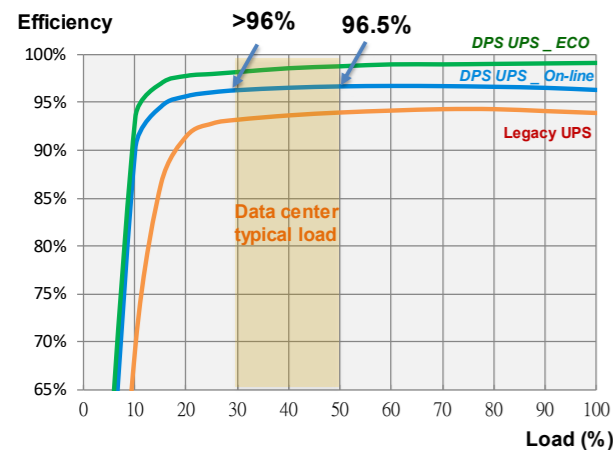

- AC-AC peak efficiency 96.5%
- The Ultron DPS is up to 96% efficient at light load conditions
- Efficiency 99% in ECO mode
- Supports UPSs operating in parallel at ECO mode

## Ready for Li-ion Batteries

With accumulated experience in power and thermal management, Delta's Lithium ion battery solution for UPS systems is a high value, innovative energy storage protection solution for data centers and critical infrastructure.

- Significantly reduced battery footprint and weight allow for a more effective use of space.
- Double the life and simpler maintenance compared to traditional batteries.
- Reduced cooling requirements.
- Improved backup storage predictability and manageability (Battery Management System is included).
- Reduced total cost of ownership (TCO).



# Ultimate Availability for Mission Critical Operations

The Ultron DPS series is Delta's next-generation monoblock UPS system, designed with enhanced availability, performance and manageability. In terms of availability, the DPS series support parallel configuration for redundancy and expansion to avoid single points of failure, and its self-diagnosis and event analysis functions can notify IT managers when foreseeable errors occur, and allow preventive maintenance. Along with the fully-front access design, the MTTR (Mean Time to Repair) can be significantly reduced.

## Advanced Event Analysis

The DPS series offers key parameters and waveform records supporting advanced event analysis and diagnosis.

- Event triggers: Mode transfer / System shutdown / Charger turn-off abnormally
- Recorded parameters: Output voltage, current wave display, battery voltage, DC bus voltage, input voltage

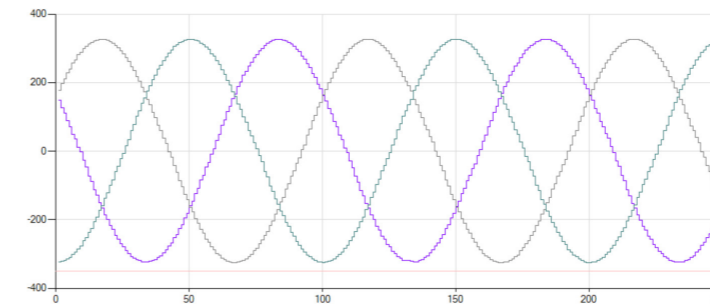

Software: Delta Black Box

## Proactive Detection of Key Components

The DPS series UPS owns the state-of-the-art microprocessor technology which performs proactive self-detection of key components including batteries, fans, IGBTs and AC/DC capacitors. The system can also provide a complete and detailed operating status of the UPS. When the system detects an abnormal situation, it initiates an alarm.

The battery set is critically important in the event of a power outage. Battery health is essential if operation is to continue uninterrupted. Ultron DPS UPS systems can carry out proactive battery testing, perform capacity detection, and even forecast how fast batteries are aging by collecting and analyzing data.

## Easy Maintenance for Short MTTR

Fully front access and modular design of key components simplifies maintenance and shortens the mean time to repair (MTTR)

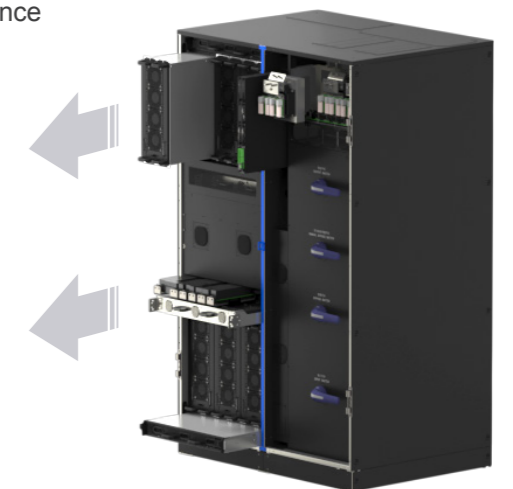

# Redundant Design for High Availability

The Ultron DPS series UPS is a highly redundant system that provides outstanding availability. By ensuring the design includes no single points of failure, Delta was able to build an extremely reliable solution. The DPS series' high availability feature achieves the best practice for optimizing the total cost of operating your data center.



## Controller & Signal Transmission

## System

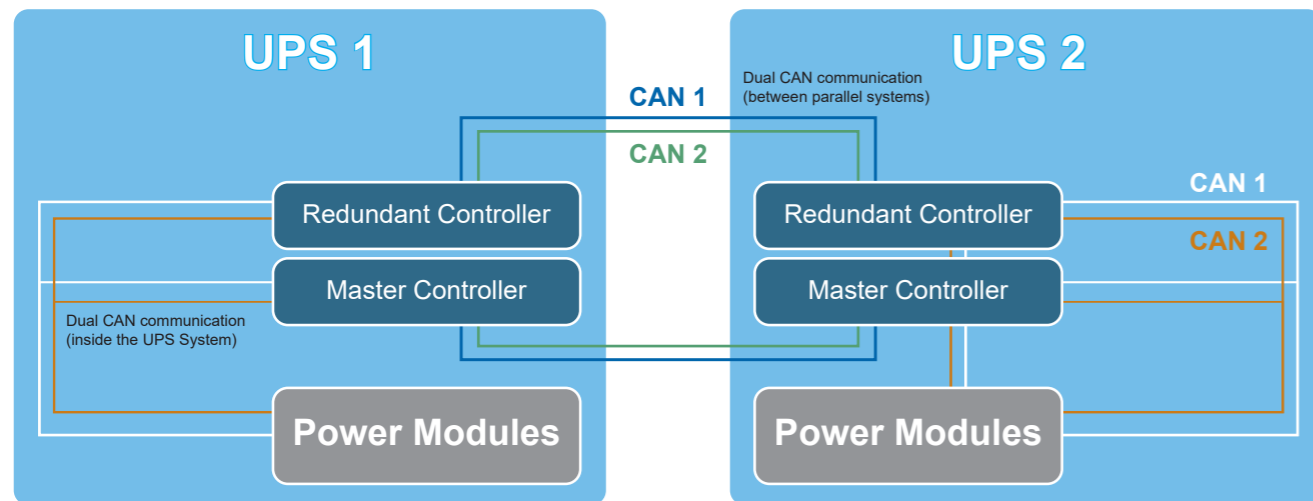

The dual controller design provides a CAN bus redundancy, either inside the UPS system or between parallel systems as a daisy chain or ring connection.

Up to **9.6 MW**



Parallel expansion and N+X redundancy can be implemented to meet the power requirements of MW-level data centers. Ultron DPS series UPS systems grow with your business via parallel expansion with up to 8 units for 9.6 MW of total capacity.

Expanded relay I/O card and multifunctional communication card (optional)



Dual controllers ensure reliable communication and enable parallel system redundancy and synchronization.

Dual auxiliary power ports ensures a continuous power supply.

# High Manageability



Delta's DPS series UPS offers the ability to view up to 10,000 event logs on the touch panel. The unit's 10" LCD screen can optionally display information on security, cooling, fire protection, and temperature in addition to battery status. The availability of all this information on the touchscreen of the UPS allows for easy local management.

## Battery Management System

If the UPS is equipped with an external battery management system, the battery information (including battery charge/discharge current, voltage, resistance and environment temperature) can be integrated into the UPS and monitored via the LCD of the UPS. It is also compatible with other vendors' BMS hardware through open protocol interface and firmware customization.

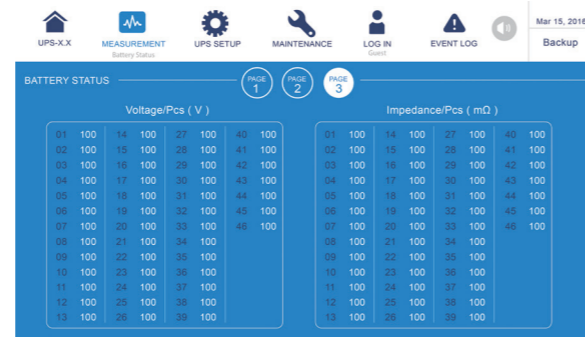

## Environment Management System

Up to 16 pieces of EnviroProbe can be connected to UPS via Ethernet for data collection such as security, water, fire and temperature.



## Power Consumption Management

For better facility management, facility managers can monitor the power consumption and get a detailed energy usage analysis to understand the electricity tariff history by day / week / month / year.



Delta's InfraSuite Manager DCIM solution is also available as an option for more comprehensive data center infrastructure management.

# Technical Specifications

Model	DPS-300k	DPS-400K	DPS-500K	DPS-600K	DPS-800K	DPS-1000K	DPS-1200K	
Power Rating	kVA	300	400	500	600	800	1000	1200
	kW	300	400	500	600	800	1000	1200
Input	Nominal Voltage	220/380V, 230/400V, 240/415V (3-phase, 4-wire + G)						
	Voltage Range	176/304~276/478 VAC (full load)						
	Current Harmonic Distortion	<3% (with Full Linear Load); <5% (with Full Non-linear Load)						
	Power Factor	> 0.99						
	Frequency Range	40 ~ 70 Hz						
Output	Voltage	220/380V, 230/400V, 240/415V (3-phase, 4-wire + G)						
	Voltage Harmonic Distortion	<1.5% (Linear Load); <5% (Non-linear Load)						
	Voltage Regulation	±1% (static); ±5% (dynamic)						
	Output Power Factor	1						
	Frequency	50/60Hz (Auto-Selectable)						
	Overload Capability	≤ 125%: 10 min; ≤ 150%: 1 min; >150%: 1 sec						
Display	10" Color Touch Panel							
Interface	Standard	RS232, Parallel port, USB, Modbus RS485, Input dry contact, Output dry contact, SNMP card inbuilt in touch screen						
	Optional	Relay I/O card, Battery cabinet temperature sensor cable						
Conformance	Safety	CE						
Efficiency	AC-AC Mode	Up to 96.5%						
	ECO Mode	99%						
Battery	Type	VRLA, LiB						
	Charge Current	90A	120A	150A	180A	240A	300A	360A
	Battery Quantity	30 – 46 pcs						
Environment	Operating Temperature	0 ~ 40°C						
	Relative Humidity	0 ~ 95% (non-condensing)						
	Audible Noise	<80 dB						
	IP Protection	IP 20						
Others	Parallel Redundancy and Expansion	Maximum 8 units						
	Emergency Power Off	Remote and local						
Physical	Dimensions (W x D x H)	600 mm*	1200 mm*	1200 mm*	1200 mm*	1800 mm	2450 mm	2450 mm
		900 mm	900 mm	900 mm	900 mm	900 mm	900 mm	900 mm
		2000 mm	2000 mm	2000 mm	2000 mm	2000 mm	2000 mm	2000 mm
	Weight	515kg	700kg	811kg	970kg	1270kg	1850kg	2000kg

\* The width is for the cabinet which has four inbuilt switches.  
\* For DPS 300 kVA, only top cable entry is available.



DPS series 300-600kVA is highly integrated with four built-in switches as standard model



Fully front access and modular design of key components simplifies maintenance and shortens the mean time to repair (MTTR)



User-friendly 10" color touch screen

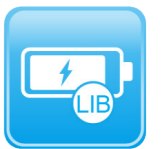

Ready for Li-ion Batteries

# Data Center Solution Offering

Delta's InfraSuite offers a comprehensive, modular and highly integrated portfolio to support the creation of high-performance data centers. As a global leader in thermal and power management solutions, Delta has further strengthened its leading position in data center infrastructure with a complete offering of AC or DC power, cooling systems, monitoring platforms from micro and modular to containerized solutions.

## Our Service and Capability

- Provides total data center life cycle services, including consulting, design, simulation, implementation and after service.
- Designs and builds data centers per customer requirements using optimal solutions.
- Offers comprehensive power supply, power distribution, cooling system, modular racks and DCIM solutions for implementation anywhere.

	<ul style="list-style-type: none"> <li>• Generator</li> <li>• Switch Gear</li> <li>• MV/LV Transfer Switch</li> <li>• Large UPS</li> <li>• Modular UPS</li> <li>• Rack level UPS</li> <li>• 12 / 48VDC System</li> </ul>	<ul style="list-style-type: none"> <li>• HDVC System</li> <li>• STS/ rSTS</li> <li>• PDU/ rPDU</li> <li>• Busway</li> </ul>
	<ul style="list-style-type: none"> <li>• Cooling Tower</li> <li>• Chiller</li> <li>• RowCool</li> <li>• Rear Door</li> <li>• Fan Wall</li> <li>• Hot Aisle</li> <li>• Containment System</li> </ul>	
	<ul style="list-style-type: none"> <li>• DCIM</li> <li>• Building Automation System</li> <li>• Surveillance</li> <li>• Video Wall</li> <li>• Lighting</li> </ul>	
	<ul style="list-style-type: none"> <li>• OCP Rack</li> <li>• Rack</li> <li>• rPDU</li> <li>• Switch</li> <li>• DCI Router</li> </ul>	

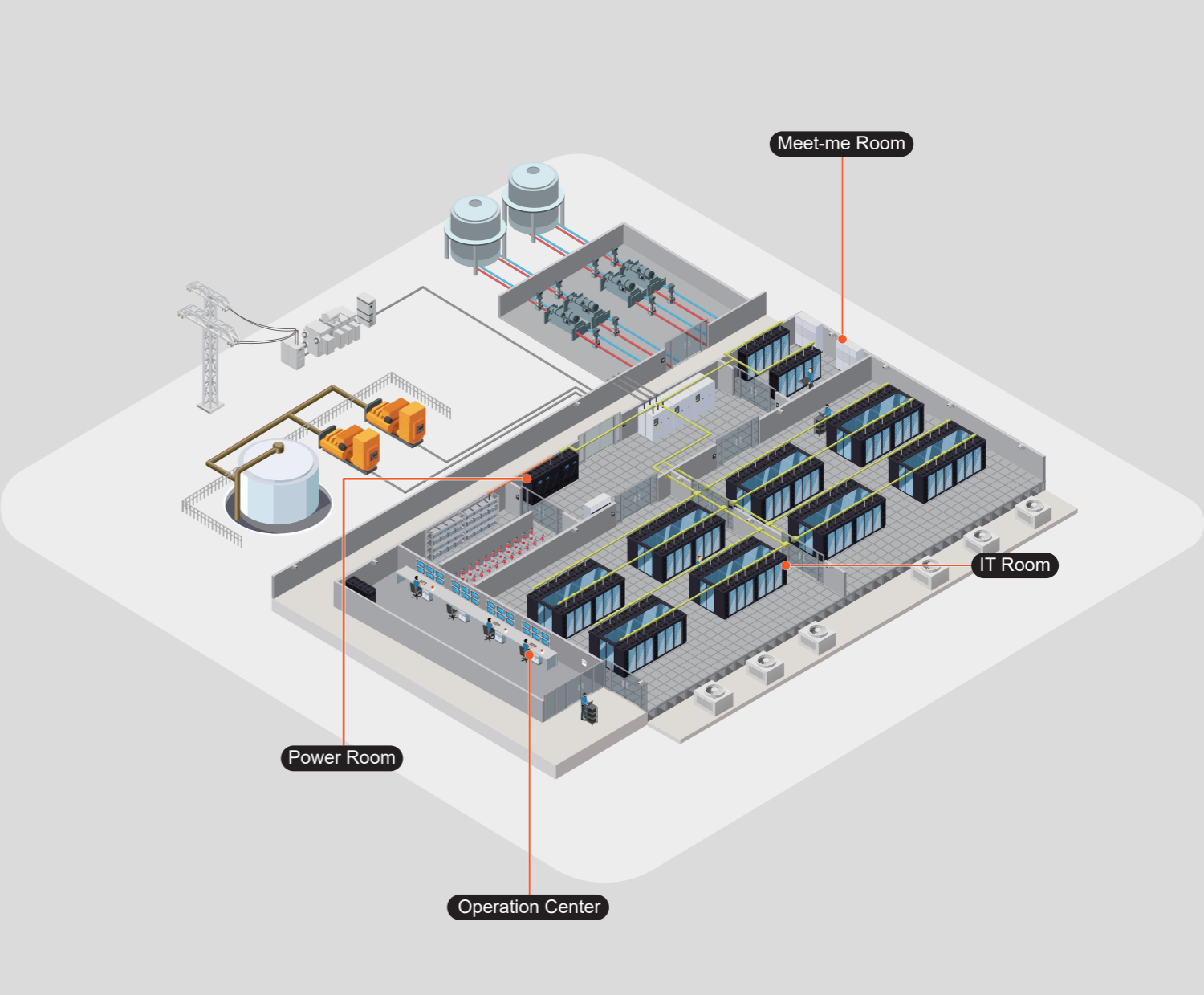

## Europe

### Czech Republic

Delta Energy Systems  
T +420 272 019 330  
E [ups.czech.republic@deltaww.com](mailto:ups.czech.republic@deltaww.com)

### Finland

Delta Solutions (Finland) Oy  
T +358 9 84966 0  
E [ups.finland@deltaww.com](mailto:ups.finland@deltaww.com)

### France

Delta Electronics (France) S.A.  
T +33 1 69 77 82 60  
E [ups.france@deltaww.com](mailto:ups.france@deltaww.com)

### Germany

Delta Energy Systems (Germany) GmbH  
T +49 2921 987 0  
E [ups.germany@deltaww.com](mailto:ups.germany@deltaww.com)

### The Netherlands - EMEA Headquarters

Delta Electronics (Netherlands) BV  
T +31 (0) 20 800 39 00  
E [ups.netherlands@deltaww.com](mailto:ups.netherlands@deltaww.com)

### Poland

Delta Electronics (Poland) Sp. z.o.o.  
T +48 22 335 26 00  
E [ups.poland@deltaww.com](mailto:ups.poland@deltaww.com)

### Russia

Delta Energy Systems LLC  
T +7 495 644 3240  
E [ups.russia@deltaww.com](mailto:ups.russia@deltaww.com)

### Slovak Republic

Delta Electronics (Slovakia) s.r.o.  
T +421 2 6541 1258  
E [ups.slovakia@deltaww.com](mailto:ups.slovakia@deltaww.com)

### Switzerland

Delta Electronics (Switzerland) AG  
T +41 31 998 53 11  
E [ups.switzerland@deltaww.com](mailto:ups.switzerland@deltaww.com)

### Spain

Delta Electronics Solutions (Spain) SLU.  
T +34 91223 7420  
E [ups.spain@deltaww.com](mailto:ups.spain@deltaww.com)

### Turkey

Delta Greentech Electronic San. Ltd.  
T +90 216 499 9910  
E [ups.turkey@deltaww.com](mailto:ups.turkey@deltaww.com)

### United Kingdom

Delta Electronics Europe Ltd.  
T +44 1355 588 888  
E [ups.united.kingdom@deltaww.com](mailto:ups.united.kingdom@deltaww.com)

## Middle-East & Africa

### South Africa

Delta Energy Systems MEA (Switzerland) AG  
T +27 12 663 2714  
E [ups.south.africa@deltaww.com](mailto:ups.south.africa@deltaww.com)

### United Arab Emirates

Delta Energy Systems (Switzerland) AG  
T +971 425 99 55 3  
E [info.middle-east@deltaww.com](mailto:info.middle-east@deltaww.com)

## Americas

### Brazil

Delta Greentech (Brasil) S/A  
T +55 11 3530 8658  
E [ups.brazil@deltaww.com](mailto:ups.brazil@deltaww.com)

### The United States

Delta Electronics (Americas) Ltd.  
T +1 510 344 2157  
E [ups.na@deltaww.com](mailto:ups.na@deltaww.com)

## Asia Pacific

### Australia

Delta Energy Systems Australia Pty Ltd.  
T +61 3 9543 3720  
E [ups.australia@deltaww.com](mailto:ups.australia@deltaww.com)

### China

Delta GreenTech (China) Co., Ltd.  
T +86 21 5863 5678 / +86 21 5863 9595  
E [ups.china@deltaww.com](mailto:ups.china@deltaww.com)

### India

Delta Power Solutions (India) Pvt. Ltd.  
T +91 124 4874 900  
E [ups.india@deltaww.com](mailto:ups.india@deltaww.com)

### Indonesia

E [ups.indonesia@deltaww.com](mailto:ups.indonesia@deltaww.com)

### South Korea

Delta Electronics (Korea), Inc.  
T +82 2 515 5303  
E [ups.south.korea@deltaww.com](mailto:ups.south.korea@deltaww.com)

### Malaysia

E [ups.malaysia@deltaww.com](mailto:ups.malaysia@deltaww.com)

### Philippines

E [ups.philippines@deltaww.com](mailto:ups.philippines@deltaww.com)

### Singapore

Delta Energy Systems (Singapore) Pte Ltd.  
T +65 6747 5155  
E [ups.singapore@deltaww.com](mailto:ups.singapore@deltaww.com)

### Taiwan

Delta Electronics Inc.  
T +886 6 505 6565  
E [ups.taiwan@deltaww.com](mailto:ups.taiwan@deltaww.com)

### Thailand

Delta Electronics (Thailand) Public Co., Ltd.  
T +662 709-2800  
E [ups.thailand@deltaww.com](mailto:ups.thailand@deltaww.com)

### Vietnam

E [ups.vietnam@deltaww.com](mailto:ups.vietnam@deltaww.com)

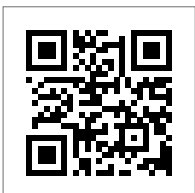

The power behind competitiveness

# Delta UPS—Amplon Family

MX Series, Line-Interactive  
1.1/2/3kVA

## Reliable Power Protection for Small and Medium Business

The Amplon MX line-interactive UPS provides pure sine-wave quality compatibility in versatile application in order to protect devices and prevent small-and-medium businesses from power failure and voltage variations in small footprint. The Amplon MX series features enhanced output power factor 0.9, AVR Efficiency up to 96.5%, resulting in a greater power supply for critical loads at significantly less operating cost.

### Availability

- Microprocessor-based line interactive design for fast response to power disturbances
- Programmable load bank disconnects non-critical loads when a blackout occurs and reserves more battery power for critical loads
- Automatic voltage regulator (AVR) delivers stable output voltage during brownouts or over-voltages
- Wide input voltage range allows the UPS to work in harsh electrical environments
- Hot-swappable battery design to protect equipment during battery replacement

### Flexibility

- Supports both rack and tower installation
- Excellent management through a user-friendly graphical and easy-shift LCD display to suit different installation format
- Supports multiple communication interfaces, including USB port, RS-232, Mini Slot, Surge Protection, REPO for enhanced monitoring and manageability

### Low Total Cost of Ownership

- Output power factor is up to 0.9 to provide more real power to critical loads
- High efficiency normal mode reach at 98% and 98.5% for 3kVA
- Wide input range and protection against over voltage prolongs battery life



School



Infrastructure



SME



Security



Telecom



Industrial



Network



Smarter. Greener. Together.

# Delta UPS–Amplon Family

## MX Series, Line-Interactive 1.1/2/3kVA

### Technical Specification

Model		MX-1.1K	MX-2K	MX-3K
<b>Power Rating</b>		1100VA / 990W	2000VA / 1800W	3000VA / 2700W
<b>Input</b>	Voltage Range	200Vac: 150-234Vac / 208Vac: 156-243Vac / 220Vac: 162-268Vac / 230Vac: 170-280Vac / 240Vac: 177-290Vac		
	Nominal Frequency	50/60Hz (Auto-Detection)		
	Connection	IEC C14	IEC C20	
	Phase	Single phase with ground		
<b>Output</b>	Voltage	200/208/220/230/240Vac		
	Voltage Regulation	±1.5% (Batt. Mode)		
	Frequency Range (Batt. Mode)	50/60Hz ± 1Hz		
	Connection	IEC C13 (4+4)	IEC C13 (4+4) IEC C19 (1)	
	Overload Capability	103~120%: 5 minutes (1 minute @ Battery mode), 120~150%: 10 seconds, >150%: UPS shutdown immediately		
	Current Crest Ratio	3:1		
	Harmonic Distortion	Linear load (full load) ≤ 2%, Non-linear load (full load) ≤ 5%		
	Waveform (Batt. Mode)	Pure Sinewave		
<b>Battery</b>	Battery Type	12V/9Ah Sealed lead-acid battery		
	Numbers	2	4	6
	Recharge Time	4 hours recover to 90% capacity		
<b>Interface</b>	Standard	RS-232 Port x 1, USB Port x 1, MINI Slot x 1, Surge Protection, REPO		
<b>Efficiency</b>	Normal Mode	98%	98.5%	
	AVR Mode	95.5%	96.5%	
<b>Environment</b>	Operating Temperature	0~40°C		
	Relative Humidity	20~90% RH (non-condensing)		
	Noise Level	< 45dBA	< 45dBA @ Normal mode, < 55dBA @ Battery mode	
<b>Physical</b>	Dimensions (W x D x H)	438 x 410 x 88mm	438 x 510 x 88mm	438 x 630 x 88mm
	Net Weight	14.1kg	21.3kg	32.1kg



User Friendly and Rotatable LCD Display



Rack/ Tower Configuration



1.1 kVA Rear View



2 kVA Rear View



3 kVA Rear View



The power behind competitiveness

# Delta UPS - Amplon Family

N Series, Single Phase  
1/2/3 kVA

## High-performance power protection with greater energy savings

The Amplon N series is a true online double-conversion UPS that can provide your critical equipment with reliable, stable sine wave power. It features significant advantages, including an output power factor of 0.9 and up to 93% AC-AC efficiency for greater energy savings. The Amplon N series provides a safe power supply guaranteed for mission critical applications such as work stations, POS, ATMs, servers, and more.

### Availability

- True online double-conversion topology and zero transfer time to battery ensure high reliability
- Advanced DSP (Digital Signal Processor) controller for fast computation capability and a simplified control circuit for enhanced stability
- Wide input voltage range allows the UPS to work in harsh electrical environments
- Generator compatibility ensures continuous and reliable power

### Green with Low TCO

- High input power factor (> 0.99) and low input harmonic distortion (iTHD < 3%) save upstream investment
- Output power factor up to 0.9 presents a stronger load capacity
- AC-AC efficiency up to 93% and high efficiency of 91% at 50% load results in marked energy cost savings
- Compact design saves more space for critical equipment

### Intelligent Management

- Excellent local communications through LCD display
- Intelligent battery management maximizes battery performance and sustains battery life
- Mini slot and USB port enhance monitoring and manageability



Server



Network



POS



Banking



# Delta UPS - Amplon Family

N Series, Single Phase  
1/2/3 kVA

Technical Specifications				
Model		N-1K	N-2K	N-3K
Power Rating		1kVA/0.9kW	2kVA/1.8kW	3kVA/2.7kW
Input	Nominal Voltage	220/230/240 Vac		
	Voltage range	175 ~ 280 Vac (full load); 80~175 Vac (50%-100% load)		
	Frequency	50/60 Hz ± 10 Hz		
	Power Factor	> 0.99 (full load)		
	Current Harmonic Distortion	< 3%		
Output	Power Factor	0.9		
	Voltage	220/230/240 Vac		
	Frequency	50/60 Hz ± 0.05 Hz		
	Voltage Harmonic Distortion	< 3% (linear load)		
	Overload Capability	< 105%: continuous; 105% ~ 125% : 1 minutes ; 125% ~ 150% : 30 seconds		
	Crest Factor	3:1		
	Receptacle	IEC C13 x 4	IEC C13 x 6, C19 x 1	
Efficiency	AC-AC	91%	Up to 93%	
Battery	Battery Voltage	24 Vdc	48 Vdc	72 Vdc
	Typical Backup Time	4.5 min.(full load); 13 min.(half load)		
	Recharge Time	3hrs to 90%		
	Charge Current	1.5A		
Audible Noise		< 43 dBA	< 48 dBA	
Display		LCD panel		
Interface		MINI Slot x 1 · USB Port x 1		
Conformance	Safety & EMC	CE/ RCM/ EN62040-1/ EN62040-2 Category C2		
Physical	Dimensions (Wx Dx H)	145 x 320 x 225 mm	190 x 390 x 325 mm	
	Weight	9 kg	18.6 kg	24.4 kg
Environment	Operating Temperature	0 ~ 40° C		
	Relative Humidity	5% ~ 95% (non-condensing)		

All specifications are subject to change without prior notice.

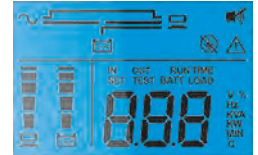

LCD Panel



Advanced UPS Management Software - UPSentry



Delta offers a full range of UPS solutions from 600 VA to 4000 kVA to fulfill your power security needs.



2007~ 2008 Forbes Asia's Fabulous 50



2009 Frost & Sullivan Green Excellence Award for Corporate Leadership



Delta's Manufacturing System is Certified by ISO 9001 and ISO 14001 Standards



IECQ Certificate of Hazardous Substance Process Management



The power behind competitiveness

# Delta UPS-Amplon Family

R Series, Single Phase

1/2/3 kVA

## Reliable power supply for small and medium enterprises

Delta's Amplon R series is an online double-conversion rack-mountable UPS providing consistent sine-wave power to your critical equipment and reliable protection for IT equipment and data centers. The R series offers an output power factor of 0.9 and a best-in-class AC-AC efficiency of up to 93% for greater energy savings. The Amplon R series leads the industry in combining compact size, availability, flexibility, and low total cost of ownership.

### Availability

- True online double-conversion topology provides zero transfer time to ensure maximum protection of the equipment
- Watch-dog design of the DSP (Digital Signal Processor) increases reliability
- Cold-start capability provides temporary battery power when the utility power is out
- Operating temperature tolerance up to 50°C ensures critical loads' continuity
- The Maintenance Bypass Box offers load continuity during battery replacement or other upgrades

### Flexibility

- Compact dimensions meet the needs of different rack cabinets
- Convertible rack and tower configuration in 2U size cabinet
- Excellent local communications through rotatable LCD display
- Intelligent management software connectivity via RS232, mini slot or USB port

### Low Total Cost of Ownership

- Wide input voltage range reduces the chance of using the battery and extends battery life
- Intelligent battery management sustains battery life and performance
- High output power factor of 0.9 provides more real power to critical loads
- High input power factor (pf > 0.99) and low harmonic distortion (iTHD < 3%) save upstream investment
- Up to 93% AC-AC efficiency and 96% efficiency in ECO mode results in marked energy cost savings
- Fan speed control by load level and room temperature optimizes performance



Server



Telecom



Industrial



VoIP



Storage



Network

 **DELTA**  
Smarter. Greener. Together.

# Delta UPS-Amplon Family

R Series, Single Phase

1/2/3 kVA

Technical Specification				
Model		R-1K	R-2K	R-3K
Power Rating		1kVA/0.9kW	2kVA/1.8kW	3kVA/2.7kW
Input	Nominal Voltage	200*/208*/220/230/240 Vac		
	Voltage Range	175 ~ 280 Vac (full load) ; 80 ~ 175 Vac (50% ~ 100% load)		
	Frequency	50/60 Hz ± 10 Hz		
	Power Factor	> 0.99 (full load)		
	Current Harmonic Distortion	< 3%		
Output	Power Factor	0.9		
	Voltage	200*/208*/220/230/240 Vac		
	Voltage Regulation	± 1% (linear load)		
	Frequency	50/60 Hz ± 0.05 Hz		
	Voltage Harmonic Distortion	< 3% (linear load)		
	Overload Capability	< 105%: Continuous; 105 ~ 125%: 1 minute; 125 ~ 150%: 30 seconds		
	Receptacle	IEC C13 x 4	IEC C13 x 6 IEC C19 x 1	IEC C13 x 6 Terminal
Efficiency	AC-AC	91%	Up to 93%	
	ECO Mode	95%	Up to 96%	
Battery	Battery Voltage	24 Vdc	48 Vdc	72 Vdc
	Charge Current	4A (up to 8A with optional inbuilt charger)		
Audible Noise**		< 40 dB	< 43 dB	< 43 dB
Display		LCD display and LED indicators		
Communication Interfaces	Standard	Mini Slot x 1, RS-232 Port x 1, USB Port x 1		
Conformance	Safety	CE		
Physical	Dimensions (Wx Dx H)	440 x 335 x 88 mm	440 x 430 x 88 mm	440 x 430 x 88 mm
	Weight	5.3 kg	9.0 kg	9.1 kg
Environment	Operating Temperature	0 ~ 50°C***		
	Relative Humidity	5 ~ 95% (non-condensing)		

\* When the UPS is de-rated to 90% of its capacity.

\*\* If the UPS is running at <75% load and in room temperature.

\*\*\* When the operating temperature is at 40~50°C, the UPS will be de-rated to 80% of its capacity.

All specifications are subject to change without prior notice.



User-friendly LCD Panel



Facility Monitoring Software  
InfraSuite Device Master



Delta offers a full range of UPS solutions from 600 VA to 4000 kVA to fulfill your power security needs.



2007~ 2008 Forbes Asia's Fabulous 50



2009 Frost & Sullivan Green Excellence Award for Corporate Leadership



Delta's Manufacturing System Certified by ISO 9001 and ISO 14001 Standards



IECQ Certificate of Hazardous Substance Process Management

